



GrowSpan™ Gothic Premium High Tunnels (CD and FD Models)

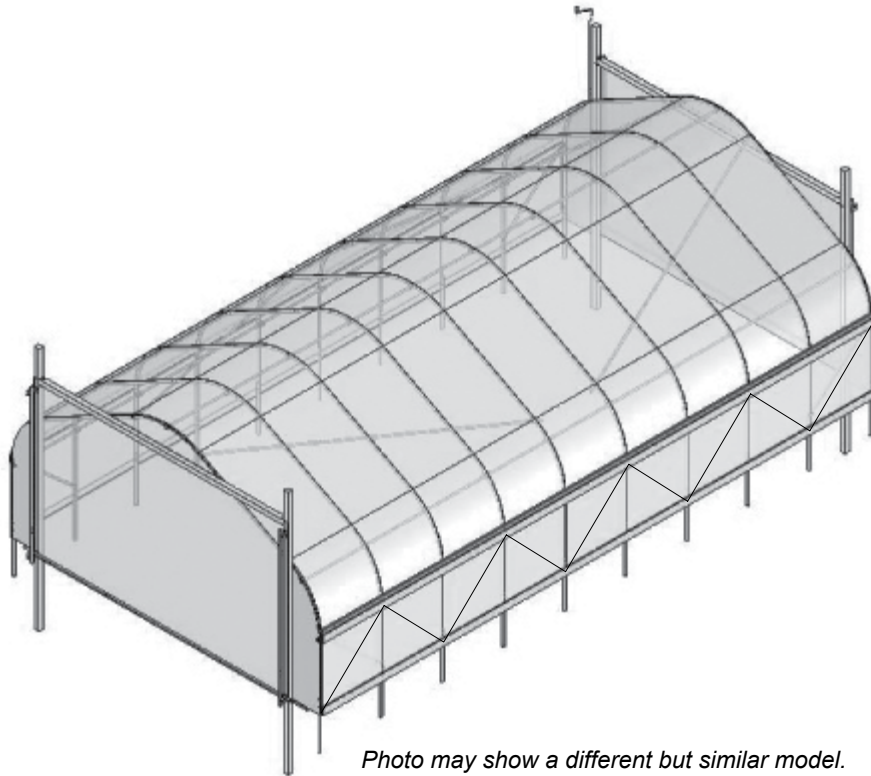

Photo may show a different but similar model.

STK#	DIMENSIONS
108179	20' W x 11' 5" H x 24' L
108180	20' W x 11' 5" H x 36' L
108181	20' W x 11' 5" H x 48' L
108182	20' W x 11' 5" H x 60' L
108183	20' W x 11' 5" H x 72' L
108184	20' W x 11' 5" H x 96' L

©2019 GrowSpan
All Rights Reserved. Reproduction
is prohibited without permission.



WARNING: Cancer and Reproductive Toxicity - P65Warnings.ca.gov

Revision date: 11.9.22



YOU MUST READ THIS DOCUMENT BEFORE YOU BEGIN TO ASSEMBLE THE SHELTER.

Thank you for purchasing this GrowSpan™ high tunnel. When properly assembled and maintained, this product will provide years of reliable service. These instructions include helpful hints and important information needed to safely assemble and properly maintain the high tunnel. Please read these instructions **before** you begin.

If you have any questions during the assembly, contact Customer Service at 1-800-245-9881 for assistance.

SAFETY PRECAUTIONS

- Wear eye protection.
- Wear head protection.
- Wear gloves when handling metal tubes.
- Use a portable GFCI (Ground Fault Circuit Interrupter) when working with power tools and cords.
- Do not climb on the high tunnel or framing during or after construction.
- Do not occupy the high tunnel or attempt to install the curtain during high winds, tornadoes, or hurricanes.
- *Never* attempt to install the curtain during windy or stormy conditions.
- Assemble and anchor the high tunnel frame *before* installing the drop-down curtain.
- Provide adequate ventilation if the structure is enclosed.
- Do not store hazardous materials in the high tunnel.
- Provide proper ingress and egress to prevent entrapment.

ANCHORING INSTRUCTIONS

Prior to assembling this high tunnel, please read the *MUST READ* document included with the shipment.

⚠ WARNING: The anchor assembly is an integral part of the high tunnel construction. Improper anchoring may cause high tunnel instability and failure of the structure. Failing to anchor the high tunnel properly *will void the manufacturer's warranty* and may cause serious injury and damage.

LOCATION

Choosing the proper location is an important step before you begin to assemble the structure.

The following suggestions and precautions will help you determine whether your selected location is the best location.

- Never erect the structure under power lines.
- Identify whether underground cables and pipes are present *before* preparing the site or anchoring the structure.
- Location should be away from structures that could cause snow to drift on or around the building.
- Do not position the high tunnel where large loads such as snow and ice, large tree branches, or other overhead obstacles could fall.
- *Always check local building codes before you begin.*

SITE

After choosing a location, proper preparation of the site is essential. The following site characteristics will help ensure the integrity of the structure.

- *A level site is required.* The site must be level to properly and safely erect and anchor the structure.
- If the site is not level, use footings to provide a secure base to assemble the structure. Pre-cast concrete blocks, pressure-treated wood posts, or poured footings are all acceptable when properly used. (Some shelters use ground posts or rafter feet.)
- **Drainage:** Water draining off the structure and from areas surrounding the site should drain away from the site to prevent damage to the site, the structure, and contents of the structure.

⚠ WARNING: The individuals assembling this structure are responsible for designing and furnishing all temporary bracing, shoring and support needed during the assembly process. For safety reasons, those who are not familiar with recognized construction methods and techniques *must seek the help of a qualified contractor.*

ASSEMBLY PROCEDURE

Following the instructions as presented will help ensure the proper assembly of your high tunnel. Failing to follow these steps may result in an improperly assembled and anchored high tunnel and will void all warranty and protection the owner is entitled.

The steps outlining the assembly process are as follows:

1. Verify that all parts are included in the shipment. Notify Customer Service for questions or concerns.
 2. Read these instructions, the Must Read document, and all additional documentation included with the shipment **before** you begin assembling the high tunnel.
 3. Gather the tools, bracing, ladders (and lifts), and assistance needed to assemble the high tunnel.
 4. Check the weather **before** you install the roof cover and any panels (if equipped). Do not install covers or panels on a windy or stormy day.
 5. Re-evaluate the location and site based on the information and precautions presented in the documentation included with the shipment.
 6. Prepare the site (if applicable).
 7. Assemble the frame components in the order they are presented in these instructions.
 8. Assemble the frame including the struts (if equipped).
 9. Consult the MUST READ document and properly anchor the assembled frame.
 10. Install the End Wall framing. (These are optional items for some shelter types.)
 11. Install, tighten, and secure the End Wall end panels and doors. (These are optional items for some shelters.)
 12. Install, tighten, and secure the main cover. This applies to fabric and film covers that stretch over the frame assembly.
 13. Attach the curtain components to the main frame, install the curtain, and attach the anti-billow ropes.
 14. Read the care and maintenance information at the end of these instructions.
 15. Complete and return all warranty information as instructed.
- **Band Clamp:** Clamp used to connect the end wall framing to the rafter pipe. In some cases, band clamps are also used to connect diagonal struts to the assembled frame.
 - **Clip or Fabric Clip:** A short, half-section piece of conduit (cut lengthwise) used to secure the end panel cover to the leg or rafter assembly. The clip or fabric clip is typically fastened in place using self tapping Tek screw.
 - **Conduit:** An assembly of pipes used to secure the main cover and end panels (if equipped). Purlins and some strut assemblies also consist of connected pipes to form a conduit. Each pipe joint of a conduit assembly is secured with a self-tapping Tek screw to prevent separation. Some conduit assemblies are used to secure larger end panels and main covers. These conduits typically consist of sections of PVC tubing glued at the joints.
 - **Cross Connector:** Any one of the metal brackets used to "connect" or secure a purlin to a rafter. Cross-connectors are typically pictured on the Pictorial Parts Guide page or in the Quick Start section (if present).
 - **End Panel:** Fabric or material used to cover the end wall assemblies. End wall assemblies are optional for many shelters.
 - **Must Read Document:** This document includes building and shelter anchoring instructions, steps for end wall reinforcement, safety precautions, and notices and warnings. The Must Read document is sent with all shelters and buildings. If you did not receive a Must Read document, contact Customer Service to request one.
 - **On-Center:** Term used to describe a measurement taken from the vertical center of the rafter or frame member to the vertical center of another.
 - **Purlin:** The pipe assembly that runs perpendicular to the rafters or framework that supports the main cover. Purlins are found on the sides and roof areas of the assembled frame, are evenly spaced, and typically run from the front to the back of the shelter.
 - **Plain or Straight Pipe:** A term used to describe a pipe that has the same diameter or width throughout its entire length.
 - **Strut:** A strut is usually a length of pipe with two flattened ends and is used for diagonal bracing of the shelter frame. A strut is typically secured to the frame work by special brackets and bolts.
 - **Swaged End or Swaged Pipe:** The term "swaged" refers to the tapered end of the pipe or tube. Swaged ends of a pipe can be inserted into couplers and the straight ends of other pipes.
 - **Tek Screw:** A self-tapping fastener used to secure pipe joints and to fasten brackets to rafters.

LIST OF WORDS AND PHRASES

Before you begin, it is important to become familiar with the words and phrases used in this instruction manual.

These words and phrases are common to most GrowSpan™ shelters and identify the different parts of the shelter. (Some are used in this document. Others may not apply to this particular shelter.) These terms describe the shipped parts and can also be found on the materials list/spec sheets included with the shipment. To aid in the assembly, read through the following definitions before you begin to assemble your shelter.

GROWSPAN™ GOTHIC PREMIUM HIGH TUNNELS

SHELTER ACCESSORIES AND CONSTRUCTION SUGGESTIONS

The diagram below describes accessories available for your building and suggests ways to improve the stability of the customer-supplied end framing. Contact your sales representative to purchase or to learn more about accessories.

Stay Cable System

The Stay Cable System provides additional support to the building frame and customer-supplied end framing. When properly installed, stay cables help stabilize the main frame and end wall frame, especially in areas where strong winds are common.

Stay Cable Systems are shipped complete with cable, turnbuckles, and all the necessary clamps to secure the cable to the building, end frame, and ground anchors.

Contact your sales representative to learn more about the Stay Cable System.

ATTENTION: Construct the end wall frame as shown with the vertical jambs extending *above the header 18" to 24"*. This provides an anchor point for cables if you decide to install them now or in the future.

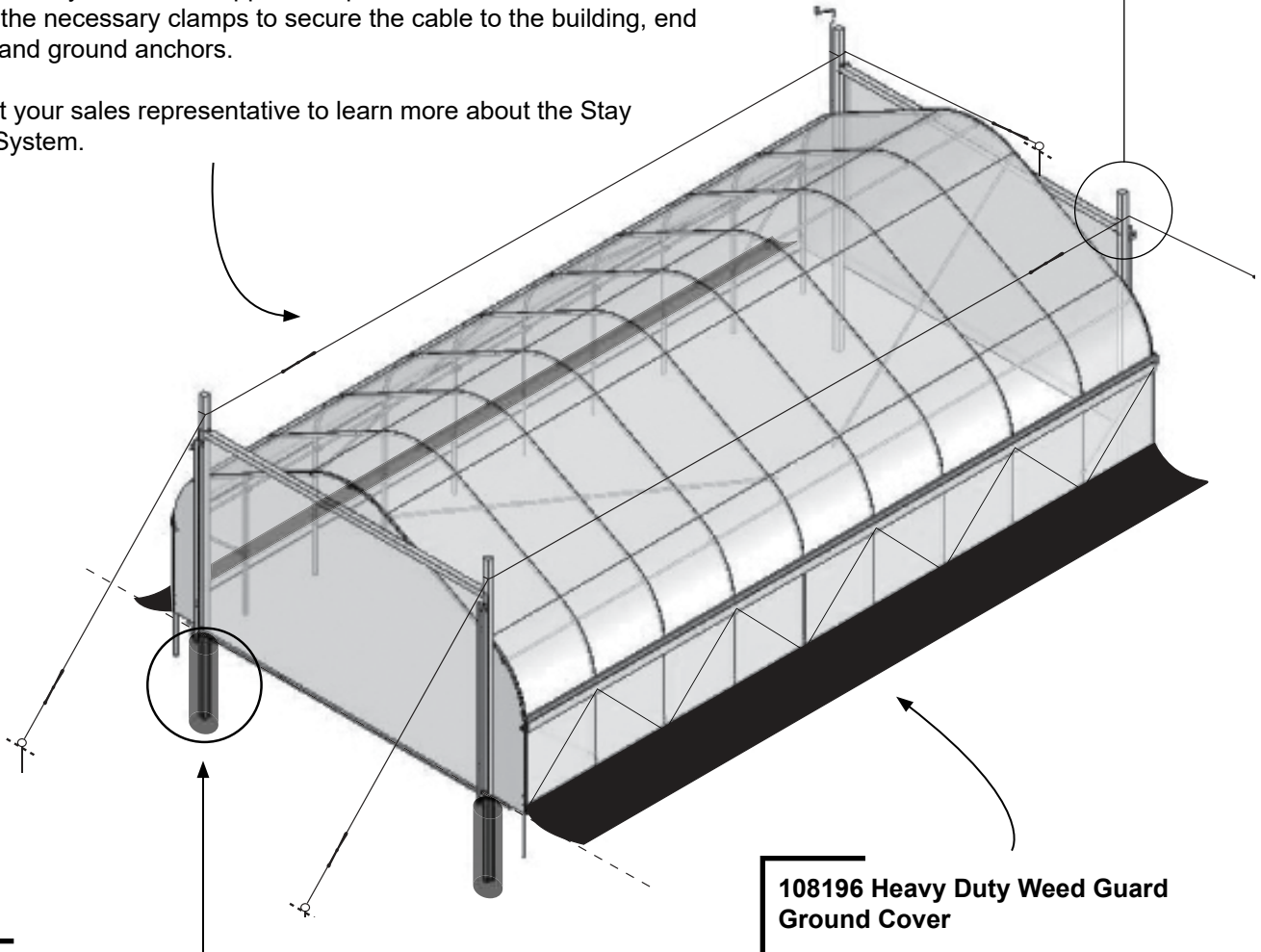

End Framing Installation

In areas where loose or sandy soil conditions are found or where deep frost is common, setting the customer-supplied end frame posts in concrete is recommended. This helps prevent shifting and provides an additional level of stability in extreme climates and during adverse weather-related conditions.

Always consult local and regional building codes and follow construction practices common to the area when setting the customer-supplied end frame posts.

End frame materials and concrete are supplied by the customer.

108196 Heavy Duty Weed Guard Ground Cover

Premium, landscape quality, black 4.75 oz. woven needle-punched fabric is 30 mils thick and manufactured from UV-resistant polypropylene.

The 108196 Heavy Duty Weed Guard Ground Cover is 36" wide to provide maximum weed prevention. Length is determined by building.

REQUIRED TOOLS

The following list identifies the main tools needed to assemble the shelter. Additional tools and supports may be needed depending on the structure, location, and application.

- Tape measure or measuring device
- Marker to mark locations on the pipes
- Variable speed drill and impact driver (cordless with extra batteries works best)
- Metal-cutting saw
- Wrenches and impact socket set, or an adjustable wrench
- Scissors, utility knife, or tin snips
- Hammers, gloves and eye protection
- Adjustable pliers and self-locking pliers
- Ladders, work platforms, and other machinery for lifting designed to work safely at the height of the building

UNPACK AND IDENTIFY PARTS

The following steps will ensure that you have all the necessary parts *before* you begin to assemble the shelter frame.

1. Unpack the contents of the shipment and place where you can easily inventory the parts. Refer to the Bill of Materials/Spec Sheets.
2. Verify that all parts listed on the Bill of Materials/Spec Sheets are present. If anything is missing or you have questions, consult the Pictorial Parts Guide and all diagrams for clarification, or contact Customer Service.

NOTE: At this time, you do not need to open the plastic bags containing smaller parts such as fasteners or washers (if equipped).

BASEBOARDS AND RIBBON BOARDS

The drop-down curtain requires a ribbon board to secure its upper section and a baseboard to secure its lower section. The materials for these components are not included and are *supplied by the customer*.

The example shows the required ribbon board and baseboard as attached to the frame.

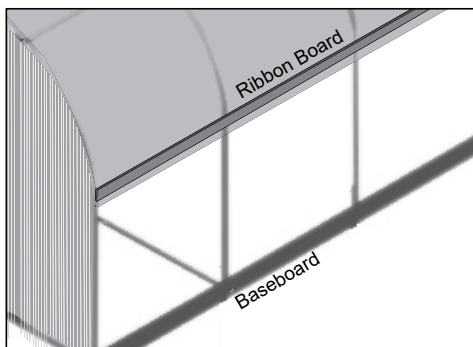

ATTENTION: Consult the Main Cover Details diagram in the Quick Start section of this manual to determine where to install the ribbon board.

The ribbon board consists of two runs of material; the first is a 2" x 6" board attached to the building frame and the second is a 1" x 4" board attached to the first board. These boards, when assembled properly, provide a channel that secures the curtain when it is in the up or closed position. Boards are secured to the frame using the supplied 1/4" x 4" carriage bolts and to each other using the FA4652 supplied fasteners.

The diagram shows a customer-supplied ribbon board as attached to the frame.

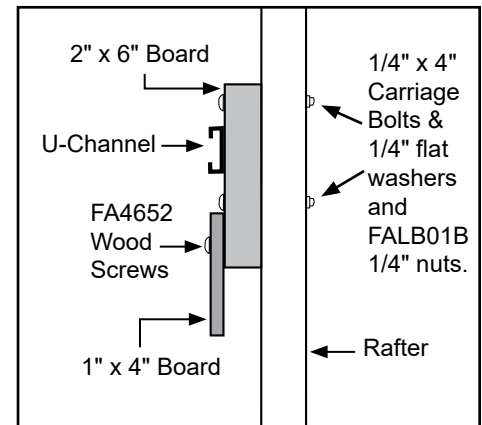

A customer-supplied baseboard and retaining board are also required to attach the curtain's lower edge. See the exploded view that follows.

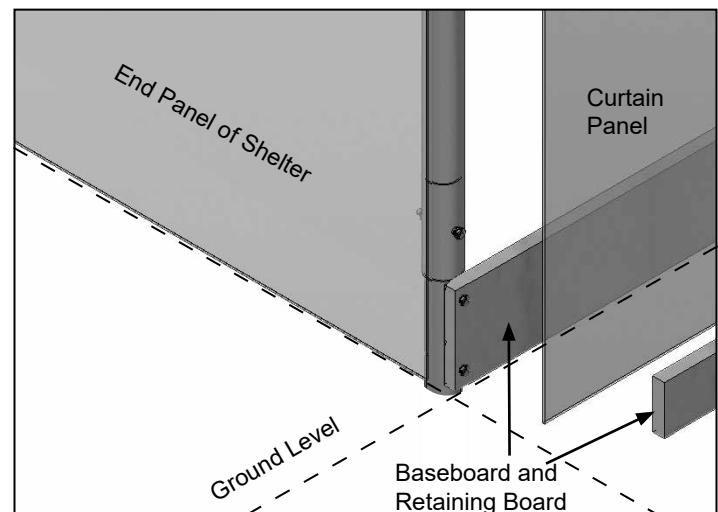

The baseboard runs the length of the frame at ground level. The retaining board secures the curtain to the baseboard. *The baseboard and retaining board are supplied by the customer.*

Fasteners (1/4" x 4" carriage bolts and FA4652 wood screws) are included. Depending on board width, use 2 carriage bolts per rafter connection for the baseboard and ribbon board. Evenly space the wood screws at 24".



The following graphics and photos will help you identify the different parts. (Some parts are not shown.)

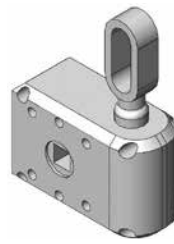

103496
Gearbox



AS5020 Pulley



FA4482B
Tek Screw



103544
Mounting Plate



102717
Gearbox Drive



102921
Neo-bonded Galvanized
Washers



102856
End Clamp



QH1402
Band Clamp

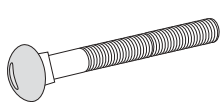

FAH009B & FALB01B
Carriage Bolt & Hex Nut



102548
Cross Connector



106734 Band Clamp

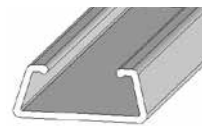

102197
Aluminum
U-Channel

MATERIAL IDENTIFICATION NUMBERS FOUND ON THE BILL OF MATERIALS

- **D10025824M**—A 6' x 8' panel used to create four (4) wind panels (2' x 6' each)—one for each corner of the frame for dropdown sides only. Material can be used to winterize the corners of buildings with rollup sides if desired.
- **DCC4931**—This number identifies the bulk material used to cover the open areas of the end frame and door frame: See End Panel Location and Door Frame Panel Location diagrams in the Quick Start section of this guide.
- **DD068HxxxCN52**—This number identifies the panels used for the drop-down curtain along each side. There are two identical panels. The xxx in the number represents the length of each panel, which is specific to each building.
- **QED108181**— This sku represents the material used for the 16"W x 10'H roll-up doors for all 20' wide buildings. There are two (2) panels of identical dimensions. These panels include a pocket at the bottom and installed grommets along each side. The top of the panel, which is attached to the door frame, is plain.
- **Main Cover**— *Buildings* with the FD identification number (e.g., 108179FD) have a 5.2oz clear fabric main cover; cover part number begins with the letters **QC**. *Buildings* with the CD identification number (e.g., 108179CD) include a film cover identified by a six digit sku number; there are no letters in the film identification number.



102198A
U-Channel Spring

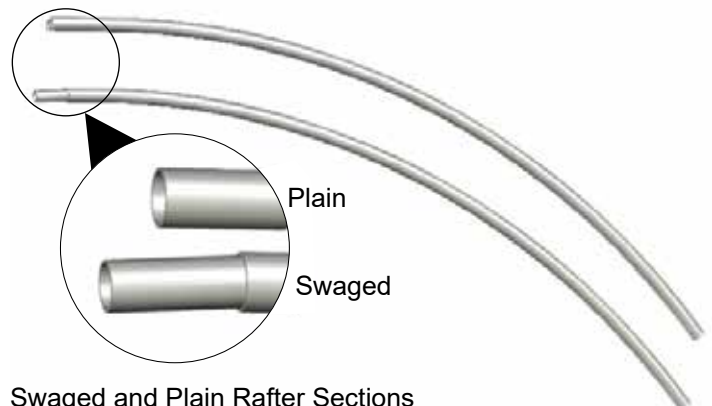

Swaged and Plain Rafter Sections

Gothic Premium High Tunnel: CD and FD Models

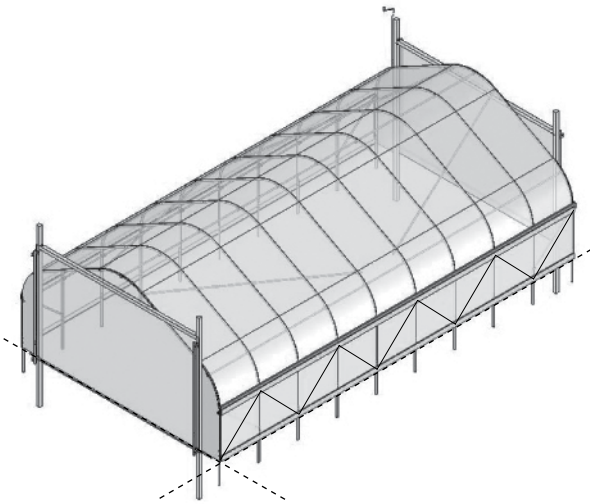

ATTENTION: These instructions describe the installation of the optional ridge vent kit. (Additional purchase required.) The ridge vent kit is designed for use with the FD model (5.2 oz. cover) only. If you have the CD model or did not purchase the ridge vent kit, skip those installation procedures when presented and continue as instructed.

Do not cut the film of the CD model to install ridge vent kit.

CUSTOMER-SUPPLIED END FRAME: Construct the end frame for the roll-up end panel using 4" x 4" wood posts. The doorframe materials are supplied by the customer. If quality 4" x 4" lumber at the lengths needed is not available, construct 2-ply wood beams using 2" x 6" boards secured together with exterior grade bolts and nuts. Center the doorframe in the end wall and dig the holes for the doorjamb.

Stagger all joints. Do not align. Use treated lumber and set in concrete for best results.

OVERVIEW

This section describes assembling your high tunnel. For details, please see section, Assembling the Frame Components. See illustration below to identify main parts of your high tunnel.

1. Locate the required parts for each assembly procedure.
2. Assemble the rafters and frame, and square the frame.
3. Prepare and attach end panels.
4. Install main cover.
5. Attach the drop-down curtain and anti-billow ropes.

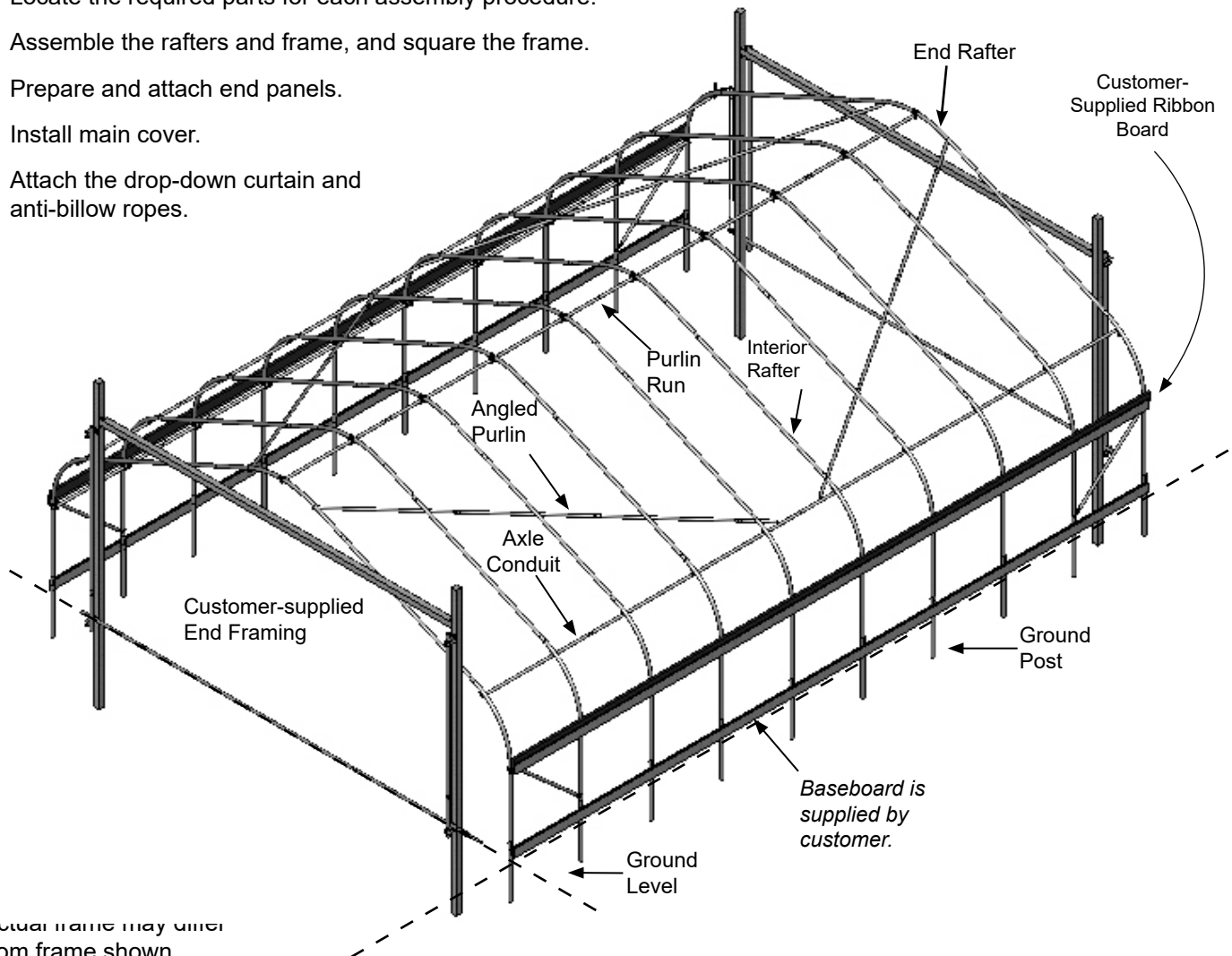

GROWSPAN™ GOTHIC PREMIUM HIGH TUNNELS

LAY OUT THE BUILDING SITE

After the site is prepared, lay out the building site.

Taking these steps *before* assembling the shelter saves time and ensures that the structure is positioned as desired.

Drive ground posts to the proper depth. Width of the shelter is measured from the center of one ground post to the center of the remaining ground post.

SQUARE THE SITE

Gather the Parts:

- Ground posts
- 5/16" x 2-1/2" Machine bolts
- 5/16" Nuts

1. Identify a corner where a ground post will be positioned and drive the first ground post into the ground.

NOTE: Insert the ground post driver into the top of the ground post to protect the post and drive the post into the ground. *The top of the post will be one (1) foot above the finished grade when properly driven.*

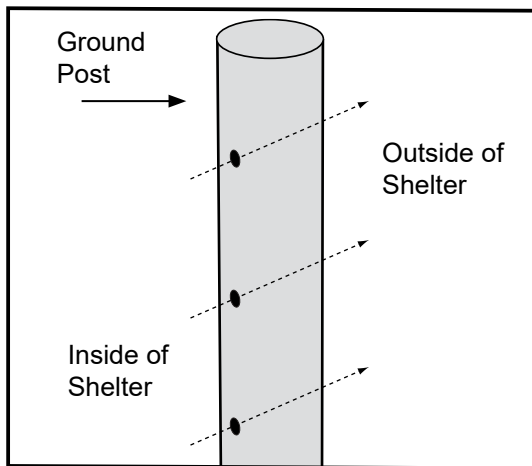

ATTENTION: Position the pre-drilled holes facing to the inside/outside of the shelter so they can be aligned with the bolt holes in the rafter legs.

To align the bolt holes in the ground posts with those in the rafter *after driving the ground posts*, insert a tapered rod or pry bar into a ground post bolt hole and turn the post using the rod or pry bar.

2. After the first corner ground post is in place, string a line the width of the building (center-to-center) and drive the second ground post into the ground just enough to hold it in place.

3. Use a transit or another method to position the second post, and to drive the post the same depth as the first ground post.
4. String a line at least as long as the building from the first stake at 90°.

NOTE: A transit can be used to ensure an accurate 90° angle, or the 3-4-5 rule can be used. Refer to diagram. Using multiples of 3-4-5 such as 6-8-10 or 12-16-20 helps to maintain an accurate 90° angle.

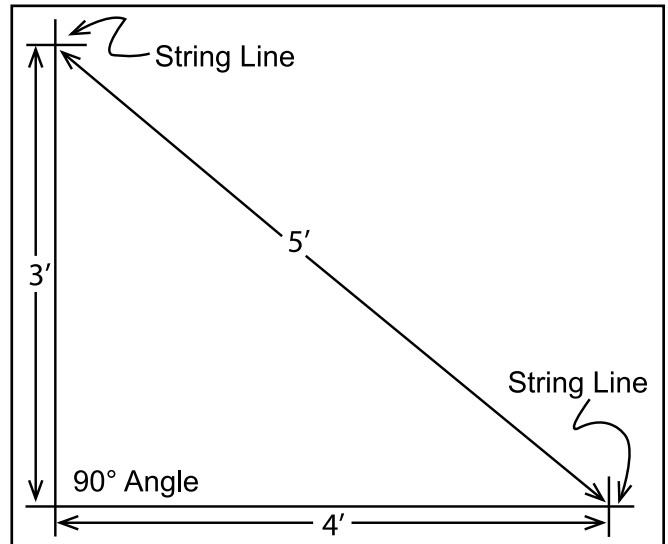

5. After squaring the position of the building, measure the length (center-to-center) and drive the next corner ground post.
6. Repeat the same step for the last corner post.

NOTE: The distance measured diagonally between corner posts must be equal for the building to be square.

7. Check all dimensions (and adjust if needed) before driving the remaining posts to the required height.
8. After all corner posts are accurately installed, tie a string line between the tops of the corner ground posts on the same side of the shelter. The string is used to identify the tops of all remaining ground posts. The string must remain tight and level.
9. Use a tape measure to mark the 48" on-center locations of the remaining ground posts.
10. Drive the remaining ground posts into the ground at the required 48" on-center width and the height identified by the string.

NOTE: Verify that the holes in the ground posts are in the proper position and that each post is plumb and driven to the correct depth.

11. Continue with the **Rafter Assembly** steps that follow.

ASSEMBLING THE FRAME COMPONENTS

After the site is prepared and an inventory of parts is complete, continue with the rafter assembly.

NOTE: All rafter assemblies consist of rafter tubes and purlin clamps. Consult the rafter diagram in the Quick Start section of these instructions before and during the rafter assembly process.

Assistance is required to assemble the high tunnel frame.

RAFTER ASSEMBLY

Gather the Parts:

- Rafter pipe (#20GT166P3)
- Rafter pipe (#20G166SS401D)
- Rafter pipe (#166S064)
- End clamps (#102856)
- Tek screws (# FA4482B)
- Nut setter 3/8" x 2-9/16" magnetic

END RAFTER ASSEMBLY

The end rafters include purlin end clamps and band clamps. Install the purlin end clamps before the different pipes of the rafters are connected. The band clamps for the side struts are installed when the two (2) end rafters are set into the ground posts.

1. Select the five (5) pipes needed to assemble the first end rafter and arrange on a level surface.

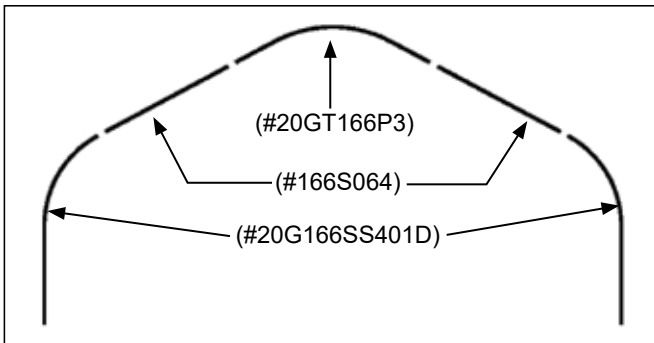

2. Slide three (3) end purlin clamps onto the peak rafter pipe and the two leg rafters. Position end clamps on the rafter pipes as shown.

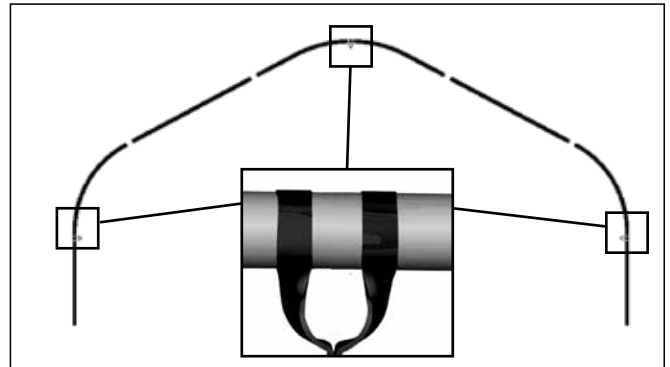

End clamp as seen from inside the assembled frame.

3. After slipping the clamps onto the rafter pipes, insert the swaged end of the rafter pipes into the plain ends of the pipes to assemble the rafter.

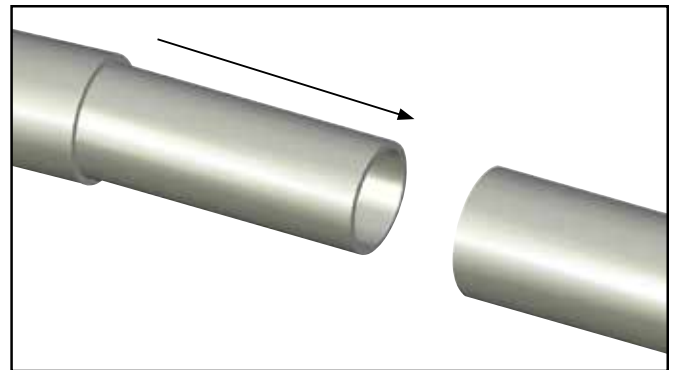

4. Once the rafter is assembled, install a Tek screw through the rafter pipes to secure each joint.

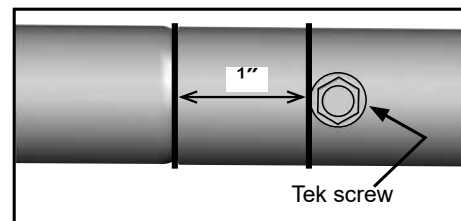

IMPORTANT: To prevent damage to the cover and end panels (if equipped), position the Tek screws so the heads do not contact the cover when it is installed.

5. Repeat steps to assemble the remaining end rafter and set both end rafters aside.
6. Continue by assembling the interior rafters. Interior rafters are assembled exactly the same, except end clamps are not used.
7. Continue by assembling the frame.

GROWSPAN™ GOTHIC PREMIUM HIGH TUNNELS

FRAME ASSEMBLY

After all ground posts are driven in place and rafters are assembled, assemble the frame.

ASSEMBLE AND PRE-MARK THE PURLINS

The following steps describe one way to speed the assembly process and eliminate the need to measure each purlin as it is installed. Pre-marking the purlins ensures that an accurate spacing of the rafter assemblies is achieved and maintained during assembly.

Gather the Parts:

- Pipe 1.315" x 75" swaged (#131S075)
- Pipe 1.315" x XX" plain (#131P0XX)
- Marker and tape measure

NOTE: The purlins are part of the assembled frame and run perpendicular to the rafter assemblies. Each purlin consists of 1.315" x 75" (#131S075) swaged pipes (number is determined by shelter length) and one (1) 1.315" x XX" (#131P0XX) plain pipe.

ATTENTION: The XX" represents the remaining length required to reach the end of the shelter. Consult the Spec Sheet for part identification.

1. Select the required pipe sections for one purlin and connect these by inserting the swaged ends of the pipes into the plain ends until the entire purlin is assembled.

NOTE: Assemble the purlins in a location that is accessible during the assembly of the frame, but will not interfere with the process of lifting and setting the rafters.

2. Verify that each pipe joint is properly seated.

NOTE: These pipes must be separated during the assembly procedure. Do not fasten them together at this time.

3. For the 48" rafter spacing, measure forty-eight and three-quarters inches (48-3/4") from one end of the assembled purlin and mark the distance on the pipe.

NOTE: This first measurement is three-quarters (3/4) of an inch longer than the on-center rafter spacing to account for the length of purlin pipe that extends through the end purlin clamp of the first end rafter.

4. From the location marked in the previous step, measure forty-eight inches (48") and make another mark on the assembled purlin.

5. Continue to mark the purlin in 48" intervals until all locations are marked. These marks help to maintain the 48" on-center rafter spacing of the shelter during assembly.
6. Repeat this procedure until all assembled purlins are marked.
7. After assembling all rafters and pre-marking the purlins, assemble the frame.

ASSEMBLE THE FRAME

After all ground posts are driven in place, rafters are assembled and purlins pre-marked, assemble the frame.

Gather the parts:

- All rafter assemblies and pre-marked purlins
 - Band clamps (#QH1402)
 - Cross connectors (#102548)
 - 5/16" x 2-1/2" machine bolts and 5/16" nuts
 - Lifts, ladders, and assistants
 - Rope or cable
1. Carefully stand the *first end rafter*, slide a band clamp onto each rafter leg, and place the leg pipes in the first set of ground posts.

Brace the rafter in place to keep it straight. Depending on the frame size, a lift and additional assistants may be needed. Consult Quick Start section for details.



Rafter shown differs in design.

ATTENTION: Stand the rafter so the nuts and bolts of the end clamps are to the inside of the frame.

FRAME ASSEMBLY (continued)

- Secure the leg pipes to the ground posts using the 5/16" x 2 1/2" machine bolts and nuts.

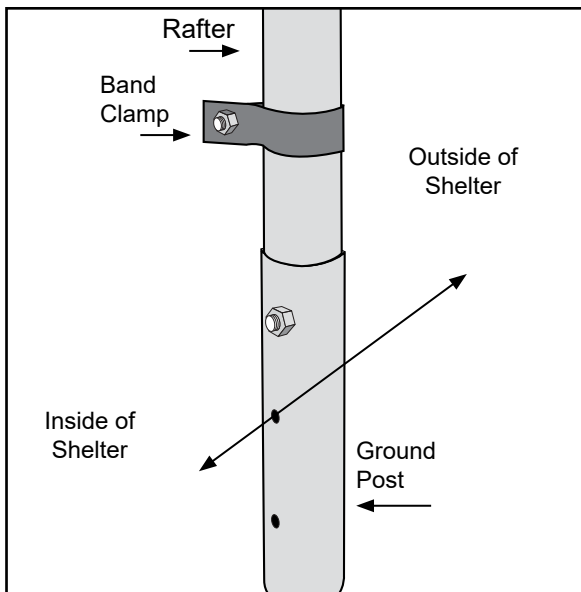

- Use rope or cable to brace the rafter in position.

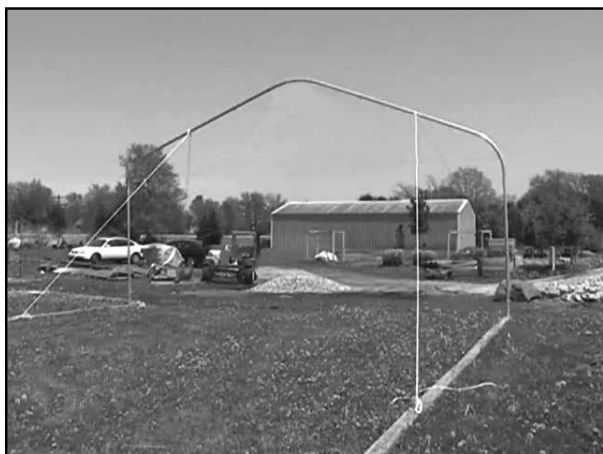

Rafter shown differs in design from actual rafter.

- Carefully stand the first interior rafter, slide a band clamp onto each rafter leg, position in place, and secure the leg pipes to the ground posts.

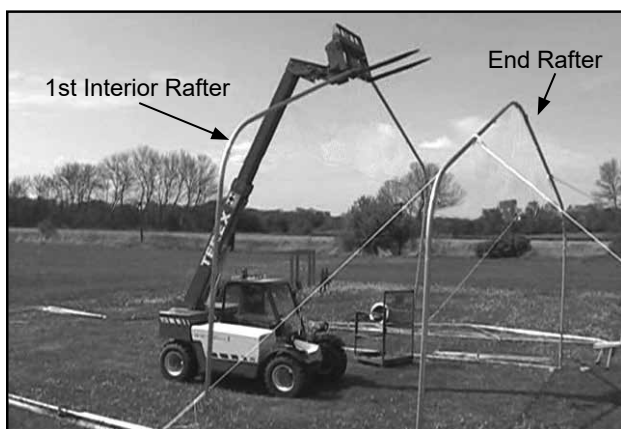

Rafter shown differs in design from actual rafter.

- As the second rafter is steadied, remove one section of pipe from one assembled purlin.

NOTE: Work from the end of the purlin where the first measurement was taken during the pre-marking procedure, if used.

- Insert the purlin pipe through the upper end clamp of the end rafter and through a cross connector placed in the same position on the interior rafter.

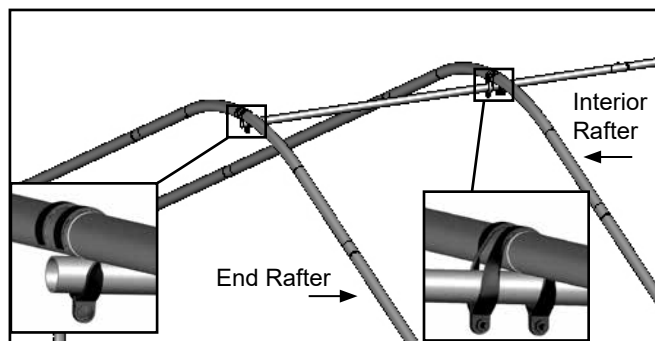

- Align the plain end of the purlin with the center of the end rafter and rotate the purlin pipe so that the first mark is visible (near the clamp of the interior rafter).

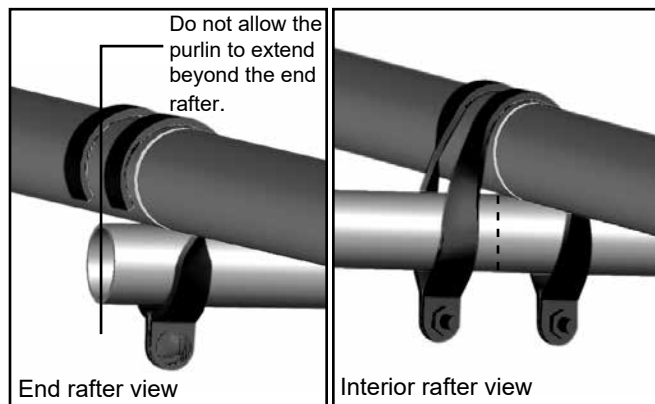

- Tighten the end clamp and secure it to the rafter with a Tek screw.
- Install Tek screw through end clamp and into the purlin pipe.

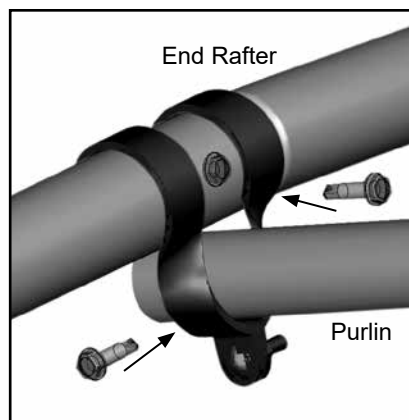

GROWSPAN™ GOTHIC PREMIUM HIGH TUNNELS

FRAME ASSEMBLY (continued)

10. Move to the interior rafter and align the mark on the purlin with the center of the rafter to maintain the proper spacing.

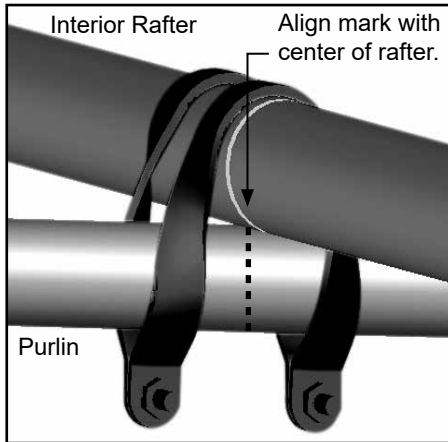

11. Verify that the rafter spacing is forty-eight inches (48") on-center (adjust as needed) and tighten the cross connector.
12. Secure the cross connector to the rafter and to the purlin using Tek screws. See Quick Start section if needed.
13. Repeat steps 5 through 12 for the remaining purlin runs.
14. Choose another interior rafter assembly and set it in position. **DO NOT USE THE REMAINING END RAFTER.**

ATTENTION: Do not add a band clamp. A band clamp is only added to the *end rafters* and the *first interior rafters* on either side.

15. Secure the rafter legs to the ground posts as previously described and steady the rafter.
16. Remove another section of purlin pipe from each pre-marked purlin assembly and attach these to the rafter.
17. Verify that the distance between the rafters is 48" center-to-center. *Adjust the rafter forward or backward as needed to maintain this dimension.*
18. Secure the purlin pipe joint with a Tek screw.
19. Repeat the above steps as needed to stand and secure the remaining interior rafters and purlins to complete the frame assembly.

NOTE: Slide a band clamp onto each leg of the last interior rafter before the end rafter.

20. Slide a band clamp onto each leg of the remaining end rafter, secure the rafter to the ground posts, and attach the purlins to the end clamps. Verify that the end clamps are positioned with the nut and bolt to the inside of the assembled frame. Refer to the Quick Start section and previous diagrams if needed.

NOTE: If the last end rafter is plumb and the purlin extends beyond the end of the rafter, cut the last section of purlin pipe to the required length.

INSTALL ANGLED PURLINS

Gather the parts:

- Pipe 1.315" x 75" swaged (#131S075)
- Pipe 1.315" x XX" plain (#131P0XX)
- Pipe straps (#QH1070)
- Tek screws and duct tape

NOTE: The angled purlins are part of the assembled frame and run diagonally across the rafter assemblies. Each purlin consists of 1.315" x 75" (#131S075) swaged pipes (number is determined by shelter length) and one (1) 1.315" x XX" (#131P0XX) plain pipe.

ATTENTION: The XX" represents the remaining length required to complete the purlin. Consult the Side Profiles for designated lengths

1. Select the required pipe sections for one purlin and connect these by inserting the swaged ends of the pipes into the plain ends until the entire purlin is assembled.
2. Verify that each pipe joint is properly seated.
3. Using the diagram below and the Side Profile diagrams in the Quick Start section as guides, position a purlin diagonally and secure to each rafter it crosses with pipe straps and Tek screws.

NOTE: Bend the pipe strap and twist as needed to fit the purlin at a diagonal angle.

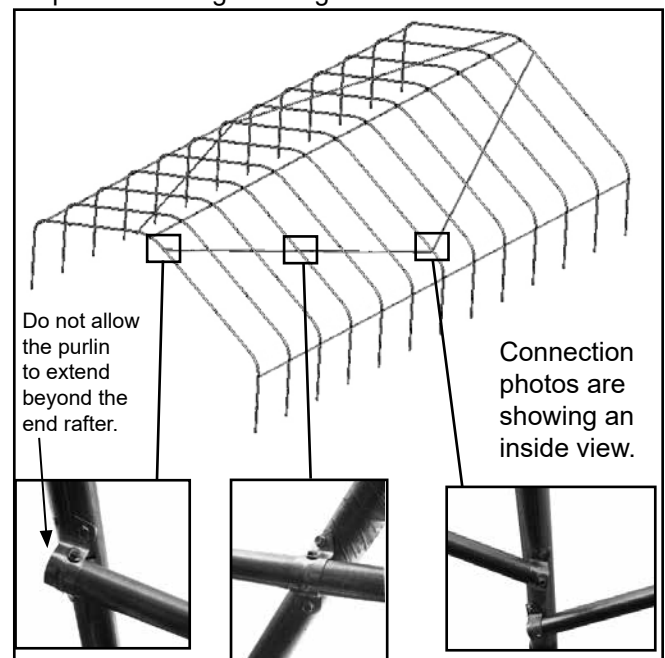

Actual frame length may differ from frame shown.

FRAME ASSEMBLY (continued)

NOTE: If two angled purlins end on the same rafter, offset the purlins to fit on the rafter as shown in the diagram below.

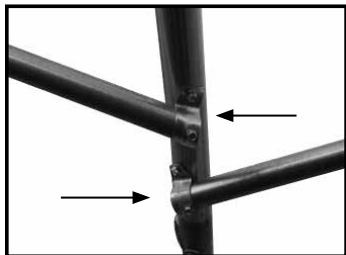

4. Verify that the purlin is in the correct position and secure the purlin to each pipe strap with a Tek screw as shown in the diagram below.

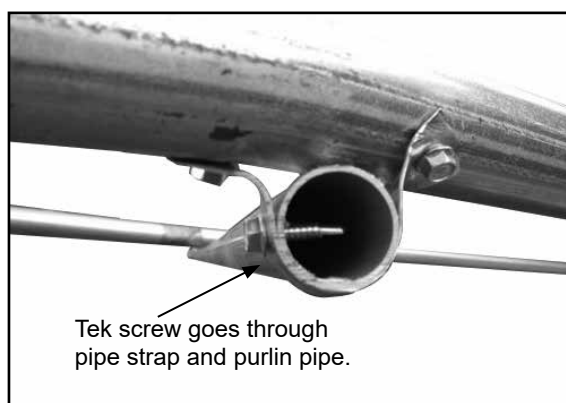

5. Repeat steps 1 through 5 for the remaining three angled purlins.
6. Once all rafters are set and all purlins are in place and secure, return to each pipe splice of each purlin and verify that a Tek screw is installed. Install a Tek screw if needed.
7. Continue by installing the baseboard.

BASEBOARD INSTALLATION

The baseboard is supplied by the customer and is attached at ground level along both sides of the frame. It helps keep the ground posts in place and also prevents the frame from working into the ground when anchored.

Attach the baseboards to the frame on the outside of the ground posts at this time.

Gather the Parts:

- Treated or recycled plastic lumber (supplied by customer).
- 1/4" x 4" Carriage bolts and 1/4" Nuts

NOTE: The following procedure describes one way to install the required baseboards. The size and type of the baseboard chosen may require the use of alternative steps. When properly installed, baseboards run the length of the frame.

On the outside of the frame, attach the first baseboard to the ground posts using the 1/4" x 4" carriage bolts and nuts. Continue adding baseboards to complete the first run. Splices are made between posts as shown. Use a short section of baseboard to secure separate baseboards at a splice.

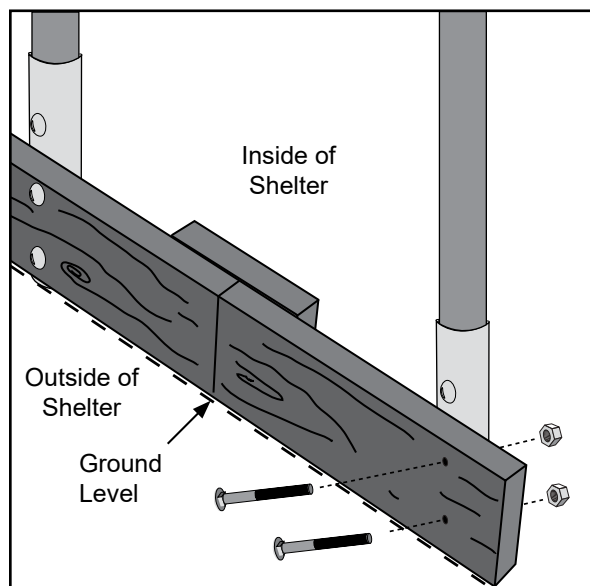

NOTE: The boards should be at ground level or slightly into grade to prevent the shelter from sinking and to create a seal along the bottom.

After installing the baseboards, continue with the installation of the side struts.

GROWSPAN™ GOTHIC PREMIUM HIGH TUNNELS

SIDE STRUT INSTALLATION

There are four (4) side struts for the shelter. These struts are positioned between the end rafters and the first interior rafter on each side of the shelter.

Complete these steps to install the four (4) side struts:

Gather the Parts:

- Struts
- Band Clamps (#QH1402)

1. Locate one strut and position it between one end rafter leg and the leg of the first interior rafter as shown below.

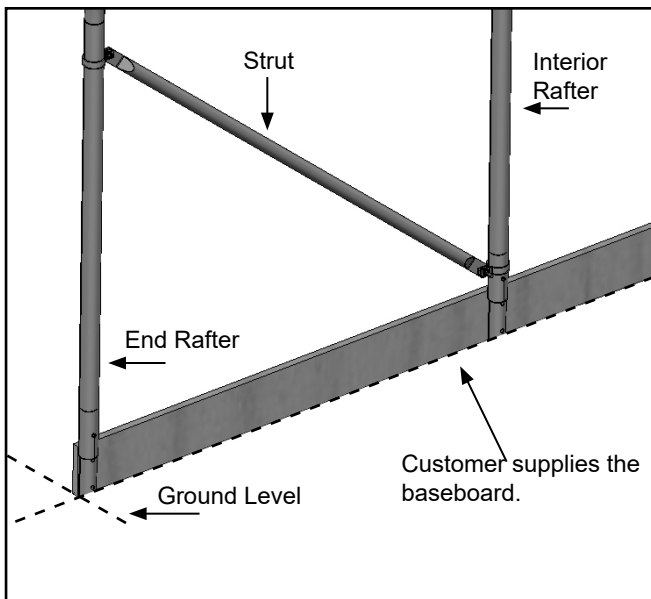

2. Attach one end of the strut to the band clamp as shown in the diagram below.

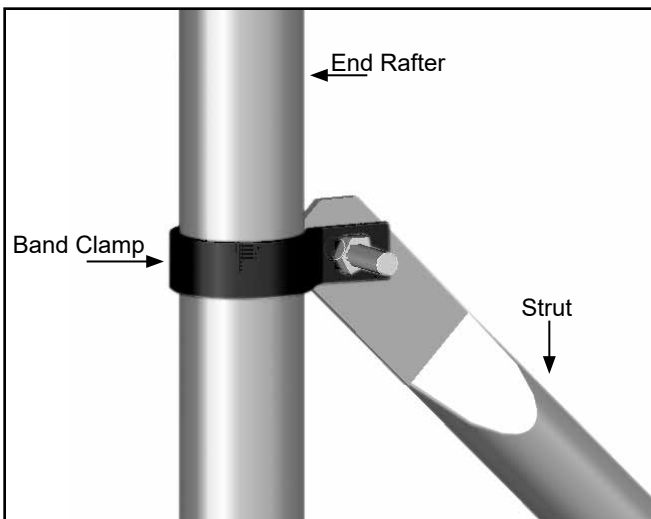

NOTE: Head of bolt on the band clamp must face toward the outside of the shelter.

3. Attach the remaining end of the strut to the added band clamp on the first interior rafter. See the diagram that follows for location.

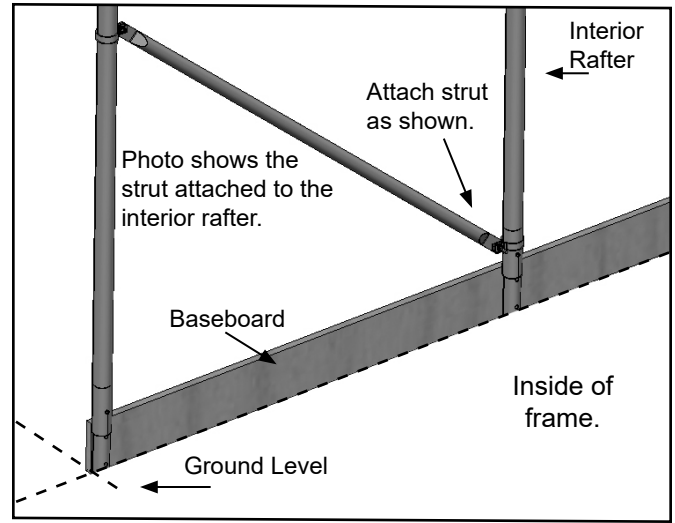

NOTE: A baseboard helps keep the ground posts at the required depth. The customer is responsible for providing a baseboard for this frame.

4. Repeat the above steps to attach the remaining side struts to the shelter.
5. After securing the struts, verify that all clamps are secured with a Tek screw to the rafters.
6. Verify that each pipe splice (purlin and rafter) is secured with a Tek screw.
7. Complete the next procedure to anchor the assembled frame.

ANCHOR THE ASSEMBLED FRAME

At this point, anchor the high tunnel frame. Consult the MUST READ document for anchoring information and suggestions. Please call customer service at 1-800-245-9881 for additional anchoring information.

CAUTION: The anchor assembly is an integral part of the high tunnel construction. Improper anchoring may cause instability and failure of the structure to perform as designed. Failing to anchor the shelter properly will void the manufacturer's warranty and may cause serious injury and damage.

After reading the MUST READ document and anchoring information, continue by installing the customer-supplied ribbon board for the drop-down curtain.

BASEBOARDS AND RIBBON BOARDS

The drop-down curtain requires a ribbon board to secure its upper section and a baseboard to secure its lower section.

ATTENTION: *The materials for these components are not included and are supplied by the customer.*

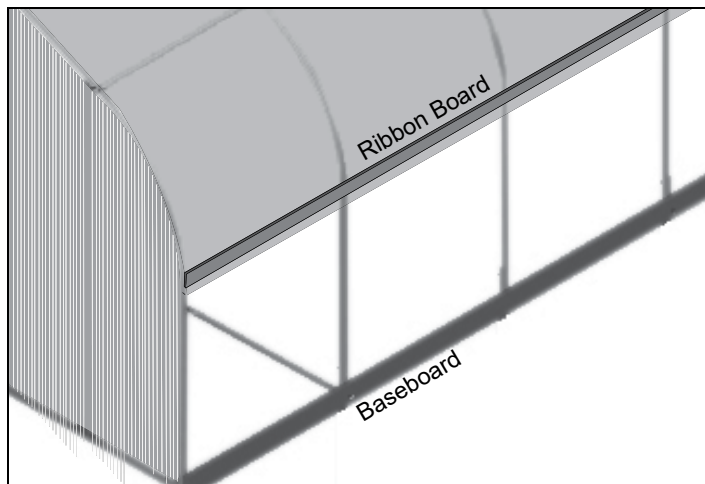

The example above shows the required ribbon board and baseboard as attached to the frame.

ATTENTION: Consult the Main Cover Details diagram in the Quick Start section of this manual to determine where to install the ribbon board.

The ribbon board consists of two runs of material; the first is a 2" x 6" board attached to the building frame and the second is a 1" x 4" board attached to the first board. These boards, when assembled properly, provide a channel that secures the curtain when it is in the up or closed position. Boards are secured to the frame using the supplied 1/4" x 4" carriage bolts and to each other using the FA4652 supplied fasteners.

The diagram shows a customer-supplied ribbon board as attached to the frame.

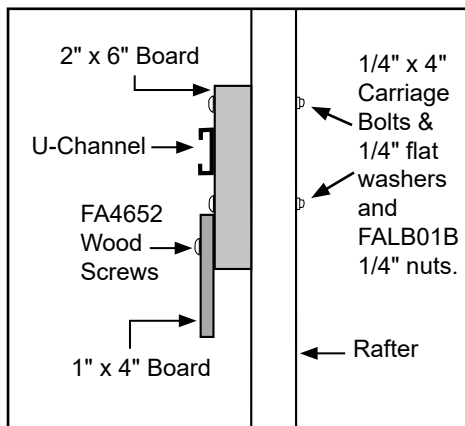

A customer-supplied baseboard and retaining board are also required to attach the curtain's lower edge. See the exploded view that follows.

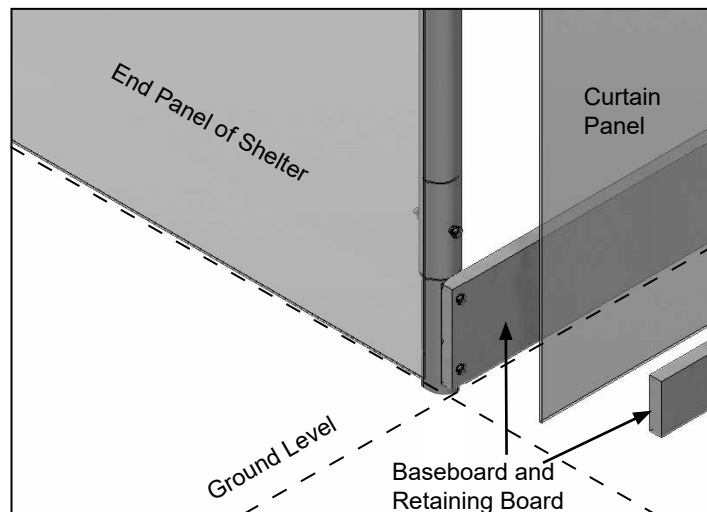

The baseboard runs the length of the frame at ground level. The retaining board secures the curtain to the baseboard. *The baseboard and retaining board are supplied by the customer.*

Fasteners (1/4" x 4" carriage bolts and FA4652 wood screws) are included. Depending on board width, use 2 carriage bolts per rafter connection for the baseboard and ribbon board. Evenly space the wood screws at 24".

FRAME CHECK AND RIBBON BOARD INSTALLATION

1. Verify that the baseboard is installed properly at ground level. The baseboard must be level for the drop-down curtain to install and function properly.
2. Gather the boards needed for the retaining board of the baseboard. See diagram above.
3. Attach the first board of the two-piece ribbon board to the frame at the required height for the curtain. See the main cover details diagram in the Quick Start section for the drop-down curtain height.
4. Use the diagram to the left to install the second board of the ribbon board. Attach to the first board using FA4652 wood screws.
5. Recheck the frame assembly for sharp edges or clamps and bolts that may interfere with the installation of the curtain. File or tape sharp edges as needed.
6. Continue with the installation of the end frame and end panels.

GROWSPAN™ GOTHIC PREMIUM HIGH TUNNELS

END FRAME ASSEMBLY

Use these steps to install the end wall supports and connecting hardware. **See note on Page 7.**

1. Using the dimensions shown on the **End Framing Details diagram in the Quick Start section**, set the customer-supplied 4" x 4" posts.

NOTE: Use recognized construction practices when setting the customer-supplied 4" x 4" posts.

2. After setting the posts, install the header. Consult the End Framing - Connections Details diagram in the Quick Start section.
3. Secure posts to end rafters as shown. Consult End Framing diagrams in the Quick Start section for details.

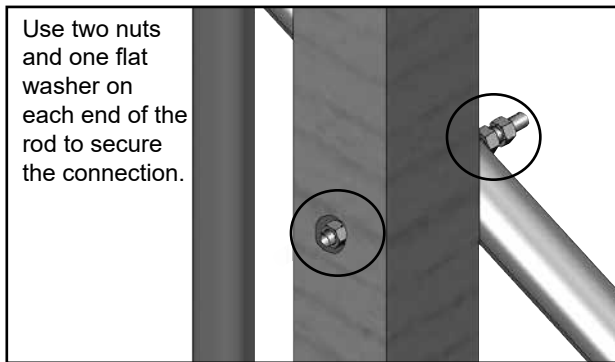

NOTE: Do not exceed 8" when cutting the individual lengths of rod from the bulk 3/8" threaded rod. Cut the threaded rod after installation. *To prevent conflicts with the end panel, countersink the "head" of the threaded rod so that it is below the surface of the customer-supplied support.*

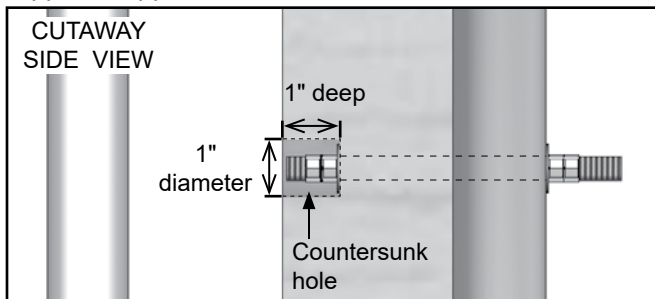

4. Repeat the steps to install the support posts and header for the remaining end wall.
5. Continue by installing the roll-up panel and guide posts.

ROLL-UP DOOR PANEL INSTALLATION (QED108181)

Before attaching the guide posts, attach each roll-up panel to the customer-supplied end framing (4" x 4") using FA4652 wood screws and neo-bonded washers. Complete these steps to install the roll-up panel conduit and hardware.

1. Take one roll-up panel, move to one end of the frame, and unfold the panel.

2. With assistance, lift and center the panel into position against the 4" x 4" end frame and attach the top to the header using wood screws and neo-bonded washers.

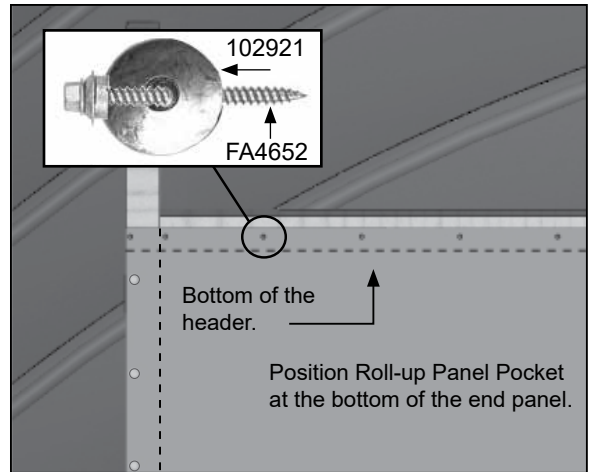

NOTE: Verify that the lower edge of the panel is on the ground before securing the upper edge to the header.

3. Refer to the End Framing diagram located in the Quick Start section to assemble the guide posts. Secure each pipe joint using a Tek screw.
4. Install the guide posts and brackets over the roll-up panel.

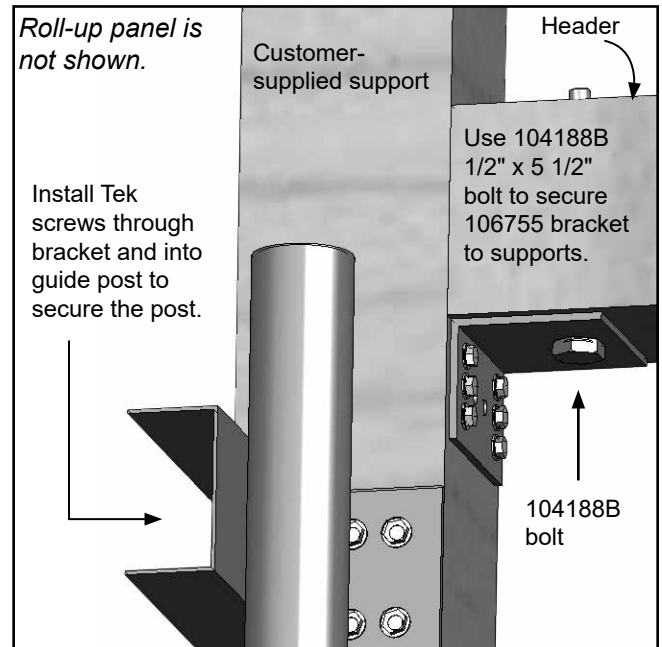

Diagram shows the guide post and bracket attached over/through the roll-up panel.

ROLL-UP DOOR PANEL INSTALLATION (continued)

5. Use the pipe diagrams on the End Framing Details diagram to assemble the crank up assembly.
6. Secure each splice using a Tek screw and cover the Tek screw with duct tape to protect the panel pocket.
7. Insert the assembly into the panel pocket. Verify that the assembly runs between the guide post and the wooden support posts. Allow a few inches to extend beyond the panel opposite the crank handle to keep the conduit in place during operation.
8. With the assembly in the proper position, flip up the skirt at the bottom of the panel to secure the conduit to the end panel using the CC6212 fabric clips and Tek screws. Divide the clips evenly between the two panels and space them evenly along each conduit.
9. Cut a vertical slice in the skirt panel to fit around the lower guide post assembly bracket. Do not cut through the end panel.
10. Test the roll-up panel.

NOTE: Verify that the 3/8" threaded rod that secures the customer-supplied end frame to the end rafter is sunk below the post surface (recommended) or has been cut off and taped to protect the panel.

11. Repeat the steps for the remaining panel.
12. After installing the door hardware and brackets, attach the end panel material to the end frame and end rafter.

END PANEL INSTALLATION—Use DCC4931 Material

Consult the **End Panel Location and Door Frame Panel Location** diagrams at the back of this manual to view the areas that need to be covered with end panel material. Use these steps to cut and attach the end panel material to the end wall frame.

1. Measure the area of the end wall that needs to be covered with end panels and cut a section from the bulk DCC4931 material. Allow extra material to achieve the best fit.

NOTE: Due to differences in construction methods and customer-supplied support materials, the customer determines the best way to prepare the bulk material for installation.

2. Set the prepared end panel in place and attach it to the end frame using FA4652 wood screws and neo-bonded washers. Attach it to the rafter using FA4482B Tek screws and neo-bonded washers (102921).
3. Repeat the steps to cut and attach the remaining end panels to cover the remaining end wall.
4. Repeat these steps to cut and attach the door frame panels.

5. After installing all end panel and door frame panel sections, install the main cover.

MAIN COVER INSTALLATION

After installing the end panels, install the main cover. The steps to install the cover include:

1. Attach poly latch U-channel along the high tunnel sides and tops of the high tunnel *end rafters*.
2. Pull the cover over the frame and attach to the end rafters.
3. Stretch and attach the cover to the sides.

INSTALL POLY LATCH U-CHANNEL

Gather the parts:

- Aluminum U-Channel (#102197)
 - FA4652 Wood Screws (spaced every 12") and FA4482B Tek screws (spaced every 12" to 16")
1. Attach one section of the poly latch U-channel to the ribbon board using FA4652 wood screws **spaced every 12"**. Attach U-channel flush with the outside edge of the ribbon board.

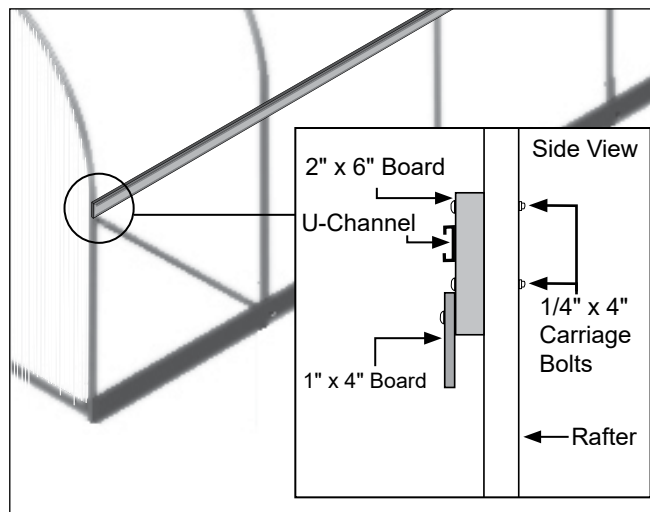

ATTENTION: Mark the wood screw locations on the U-channel (102197) sections at 12" intervals and drill the mounting holes in the U-channel using a 3/16" drill bit. Then attach the U-channel to the installed ribbon board using the FA4652 wood screws.

2. Continue to attach the U-channel sections to the ribbon board and work toward the other end of the frame.
3. Cut the last section of U-channel to the required length so that it is flush with the end of the ribbon board.

GROWSPAN™ GOTHIC PREMIUM HIGH TUNNELS

INSTALL POLY LATCH U-CHANNEL (continued)

- Repeat these steps to attach the U-channel to the ribbon board along the remaining side of the frame.
- After attaching the U-channel to the ribbon board, use Tek screws to attach the single U-channel to the top edge of the end rafters. **Space screws every 12"-16".**

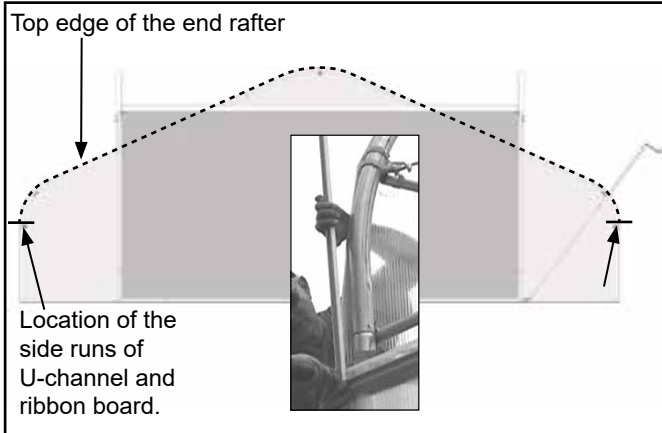

NOTE: Insert shows the installation of poly latch U-channel on top of an end rafter. The poly latch U-channel will bend with the curve of the rafter as it is attached.

- Continue to attach the U-channel until it has been installed on the top of *both end rafters*.
- Read notes that follow and continue as instructed.

OPTIONAL RIDGE VENT INSTALLATION: FD Models Only (Additional purchase required.)

Before you install the 5.2 oz. main cover (FD models only), cut the vent holes in the cover as instructed in the Ridge Vent Kit Instructions that follow.

ATTENTION: If your building is the CD model that includes the 6 mil film cover or you did not purchase the optional ridge vent kit, skip this section and continue with the installation of the main cover.

COVER DIMENSIONS

Before you cut the holes in the main cover material for the ridge vent, determine how the cover will sit on the frame. For some shelters the over-the-top measurement of the frame is greater than the length of the shelter. To avoid cutting the holes in the wrong ends of the cover material, consult the information below to cut the holes at the proper ends of the cover.

For all FD models (108179, 108180, 108181, 108182, 108183, and 108184), position the ridge vent holes at the center line along the 28' side of the raw cover material as shown. This is the over-the-top dimension.

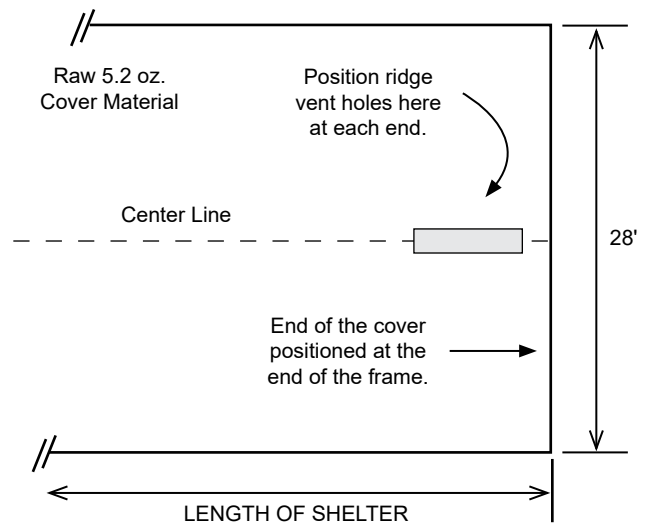

ATTENTION: Do not cut holes in your cover if you did not purchase the ridge vent kit for your building or if you have a film cover. Consult your sales representative for additional information and to purchase the kit for your building.

RIDGE VENT KIT INSTRUCTIONS

The optional Ridge Vent Kit is available *only on FD units with 5.2 oz. cover*. The kit allows control over ventilation, humidity buildup, and temperatures within the shelter.

Before installation, drill the ridge vent holes in the main cover. You will need a 3" hole saw and a customer-supplied vent hole template. Example shown to the right.

1. Identify the ridge vent location and mark a line on the center of the cover using a non-permanent marker.
2. Measure and mark 3' in from the outside edge of the cover and every 9" consecutively until you have finished the pattern shown below.
3. Place the vent hole template on the lines of the pre-marked cover, stand on the edges of the template, and carefully drill vent holes in the cover using a 3" hole saw. *Adding a scrap piece of wood under the cover for support will help keep cover tight as holes are drilled.*
4. After drilling the first set of vent holes, repeat steps for the remaining end of the cover.
5. Once the ridge vents are complete, continue with the installation of the main cover.

VENT HOLE TEMPLATE

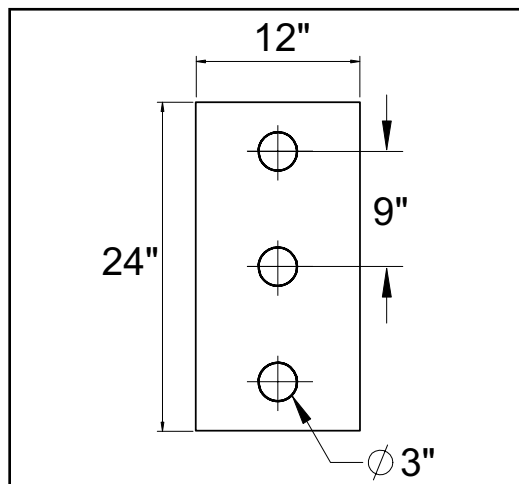

Hint: Create a vent hole template using a 12" x 24" piece of plywood. Cut 3" holes into the template as shown above. Space the three (3) holes 9" on-center.

ATTENTION: Ridge vent kits are for the FD version (5.2 oz. cover material) of the shelter only. *Do not cut holes in the film cover of the CD building model.*

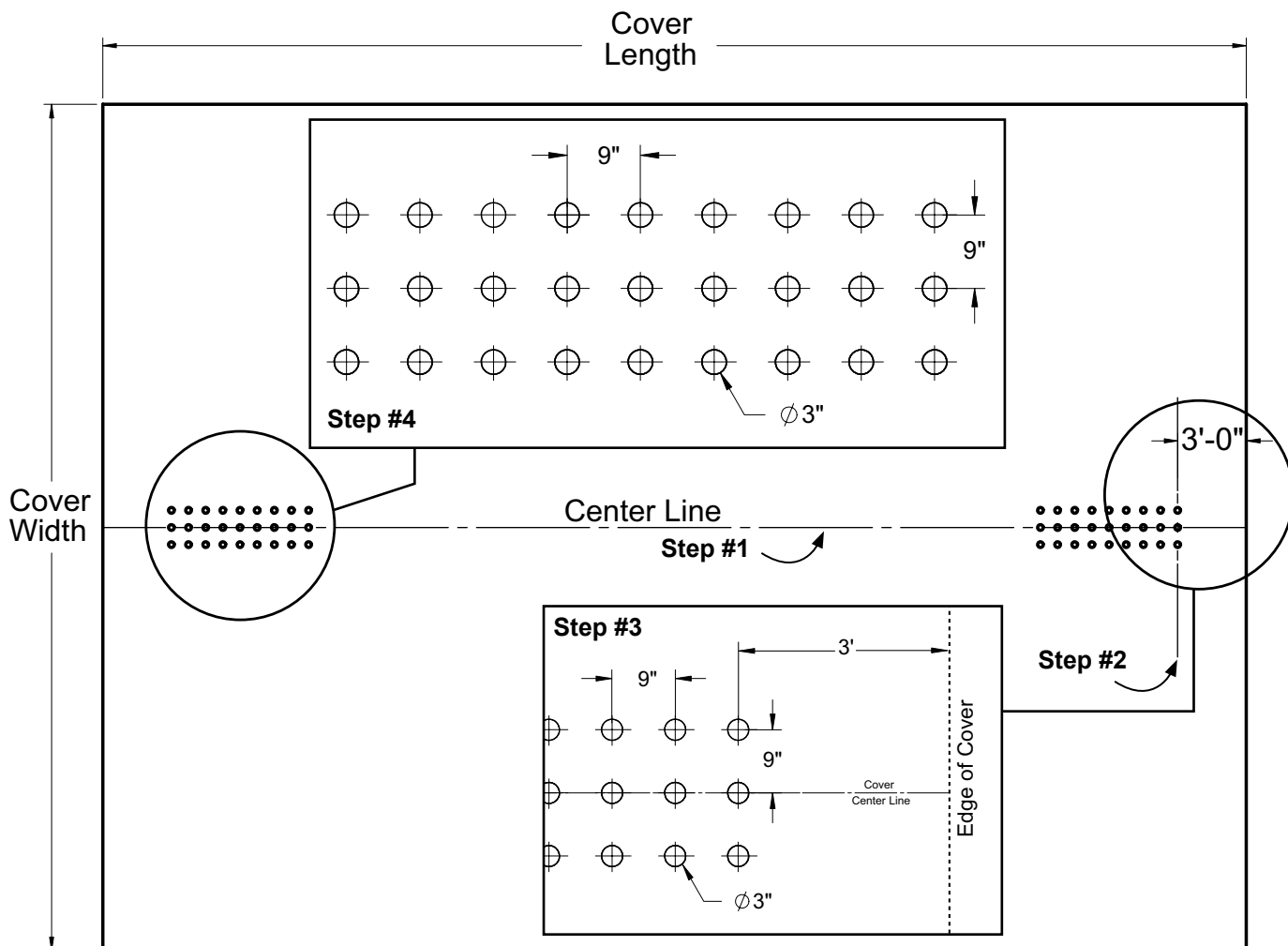

GROWSPAN™ GOTHIC PREMIUM HIGH TUNNELS

INSTALL MAIN COVER (Film or 5.2oz Clear)

Gather the parts:

- Main cover (Film or 5.2oz Clear)
- U-Channel spring (#102198A)
- Ropes long enough to reach over the frame (provided by customer)
- Box cutter or utility knife

Assembly Procedure

After attaching the poly latch U-channel, unpack the main cover and pull into place. Ropes or straps are typically used to pull the main cover onto and over the frame.

⚠ WARNING: To prevent damage to the cover and to prevent serious personal injury, DO NOT attempt to install the main cover on windy or stormy days.

The steps that follow describe one way to install the cover:

1. Take the cover and position it along the base of one side of the high tunnel.



NOTE: Unfold the cover and locate the leading edge. The frame shown in the photos that follow differs from actual frame. Procedure is the same.

Photo shows the cover in position to pull over the high tunnel.

2. Along the edge, make small holes in the cover at evenly spaced intervals and tie rope or straps to the cover.



NOTE: The ropes or straps must be long enough to reach over the top of the building to the other side. Long buildings require additional ropes to prevent tearing the main cover when it is pulled into place.

Keep the holes, used to attach the rope or straps, near the edge of the material and below where the cover will be secured to the U-channel.

3. After tying the ropes to the main cover, throw the ropes over the top of the high tunnel and pull the covers into place.

Use ropes to pull cover over the high tunnel and onto the frame. *Additional assistance is required.*

4. Center cover side-to-side and end-to-end.



Actual frame may differ from frame shown.

IMPORTANT: To prevent damage to the main cover during installation, additional personnel and lifts may be needed.

INSTALL MAIN COVER (continued)

- Once the main cover is in place and centered, begin at the peak of one end and install the wire spring into the U-channel to secure the cover.

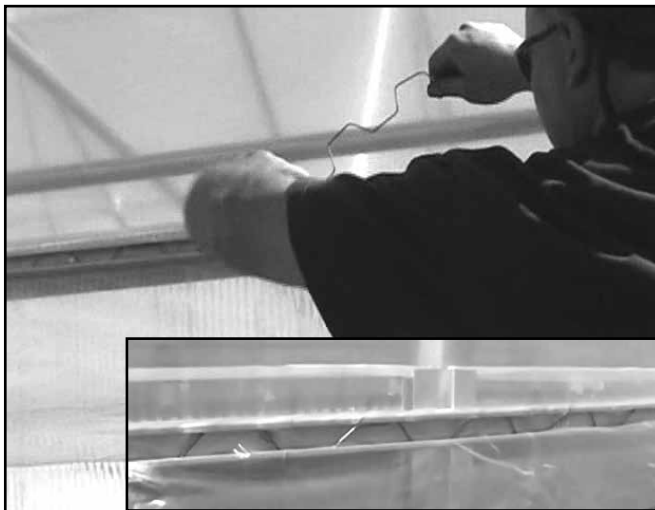

Photos show installing the spring into the U-channel on the outside of the high tunnel. The process is the same for the U-channel attached to the top of the end rafters.

ATTENTION: Center the main cover front-to-back and side-to-side to ensure that enough cover material is present to lock into the U-channel.

Remove the ropes as the covers are secured to the high tunnel.

- As the spring is installed into the U-channel at the top of the first end rafter, ensure that an even amount of the cover is exposed and maintained along the edge of the high tunnel.

NOTE: The cover material is cut longer/wider than is required to cover the high tunnel. For easier anchoring, allow approximately 10" to extend past the edge of the end rafter as the cover is anchored into place.

- Continue down both edges of the first end rafter until the entire length of the end of the main cover is secured in place.
- Move to the other end of the building and repeat the steps to secure the main cover in the U-channel.
- After the cover is stretched end-to-end and secured using the spring and U-channel, move to one side of the high tunnel and repeat the steps to secure the cover to the first side.

NOTE: Begin at one end of the U-channel and work toward the other. Another option is to begin at the middle of each side and work towards each end. Maintain an even length as working along the side. The final stretching of the cover will take place when the last side is secured.

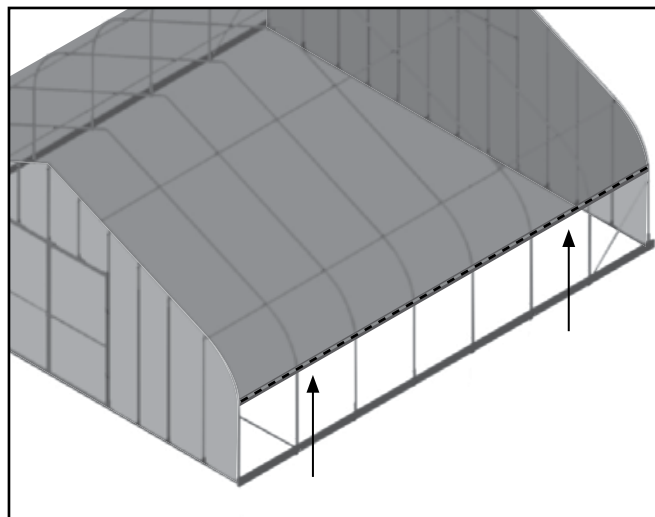

Attach main cover to poly latch U-channel. Frame shown above may differ from actual frame.

- After securing the first side, move to the remaining side, stretch the cover, and secure it in place. Pull the cover tight as the spring is inserted into the U-channel.

IMPORTANT: If trimming the excess cover material at the ends and sides, DO NOT remove too much of the excess material. Some excess main cover material (the material that extends beyond the end rafters) should remain in place to more easily re-stretch the film if needed.

- Complete the final frame check and install the drop-down curtain.

GROWSPAN™ GOTHIC PREMIUM HIGH TUNNELS

FRAME CHECK

Before you attach the drop-down curtain, inspect the frame for sharp edges or fasteners that could damage the curtain or kit components.

1. Verify that all frame members are properly secured.
2. Verify that all bolts and clamps are tight.
3. Recheck the frame assembly for sharp edges or clamps and bolts that may interfere with the installation of the curtain. File or tape sharp edges as needed.
4. Reposition clamps and bolts as needed and tape all rafter pipe joints with duct tape to protect the curtain.
5. Verify that the main building frame is properly and adequately anchored.

Do not attach the drop-down curtain to an unanchored frame.

6. Continue by installing the drop-down and its components.

INSTALL THE DROP-DOWN CURTAIN

Locate these parts to attach the pulleys and drop-down curtain axle:

- 131S075 (1.315 swaged pipe for axle) and 131P0XX (where XX represents the length needed to complete the axle assembly). See side profile for pipe identification if needed.
- 106734 band clamp
- 103496 gearbox and 103544 mounting plate
- 102717 double drive
- FA4482B Tek screws (for axle conduit)
- FAH009B (1/4" x 4" carriage bolts) and FALB01B (1/4" nuts)—use with FAME50B flat washers on the nut side.
- FAH005B (1/4" x 2" hex head bolts)
- FALF15B (1/4" lock nut) and FAME50B (1/4" flat washer)—used to secure the mounting plate.

Continue with the steps that follow to install the drop-down curtain components.

103544 Mounting Plate (Figure 1)

Actual mounting plate may differ from what is shown.

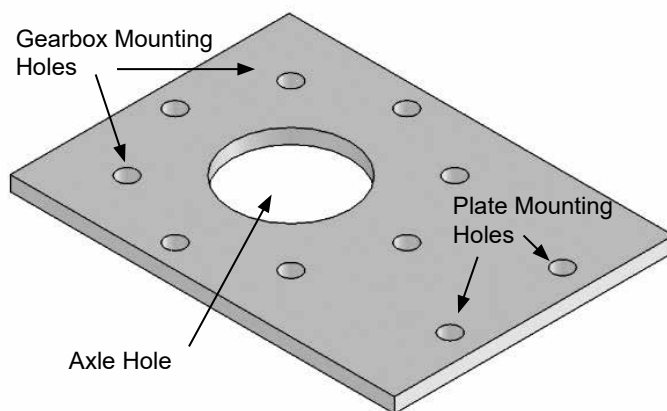

1. Take the 103544 mounting plate (shown above) and move outside the end wall where you want to position the gearbox.

INSTALL THE DROP-DOWN CURTAIN (continued)

2. Measure 12" to 24" *above the ribbon board* along the end rafter, place the mounting plate against the end wall, and align the plate mounting holes with the center of the end rafter.
3. Mark plate mounting hole locations and drill the holes. Use a 1/4" drill bit for the mounting holes.

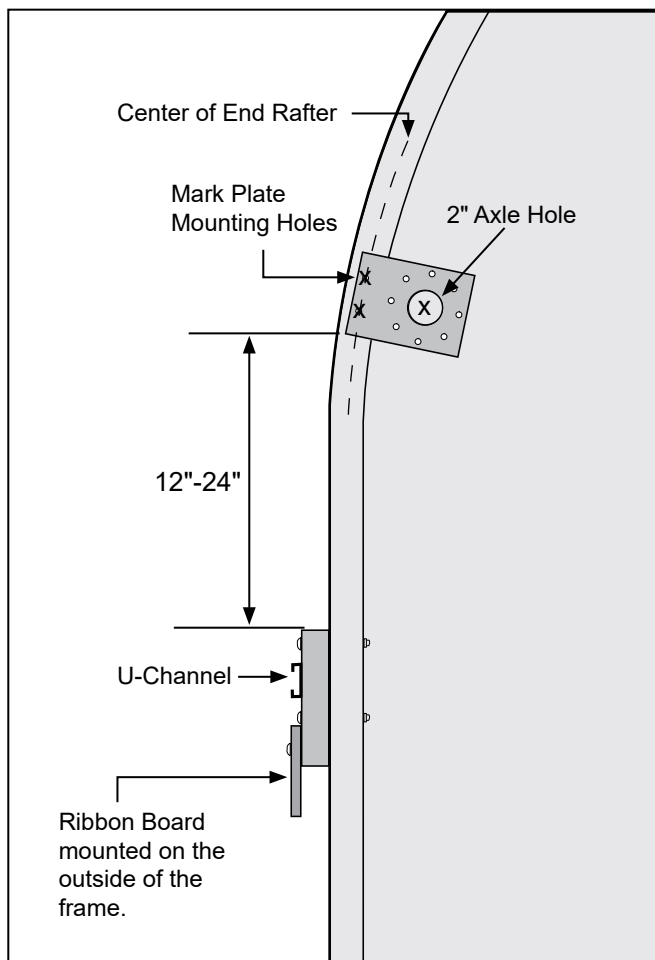

NOTE: Do not position the mounting plate in a location where purlins, clamps, or other frame components will interfere with the installation of the drop-down curtain components. *The axle mounting clamps are installed on the underside of the rafters inside the frame.*

4. Using the 1/4" x 4" carriage bolts and 1/4" nuts, temporarily secure the 103544 plate to the outside of the end wall.
5. With the plate in place, mark the location of the 2" axle hole on the end panel, remove the mounting plate, and cut the hole for the axle conduit.

NOTE: If the end wall is covered with a fabric panel, use a utility knife to cut a small X through the panel within the 2" hole position and continue.

6. With the mounting plate attached to the end rafter, take the 103496 gearbox and place it against the mounting plate at the desired angle.
7. Using a marker, trace the edges of the gearbox to mark the desired angle on the mounting plate.

NOTE: The gearbox can be tilted when mounted to the plate to allow easier access when using the crank handle.

8. Set the gearbox aside and remove the mounting plate from the end rafter
9. Using the diagram below and the marks made in Step 7, align and attach the 103496 gearbox and assemble the remaining components as shown.

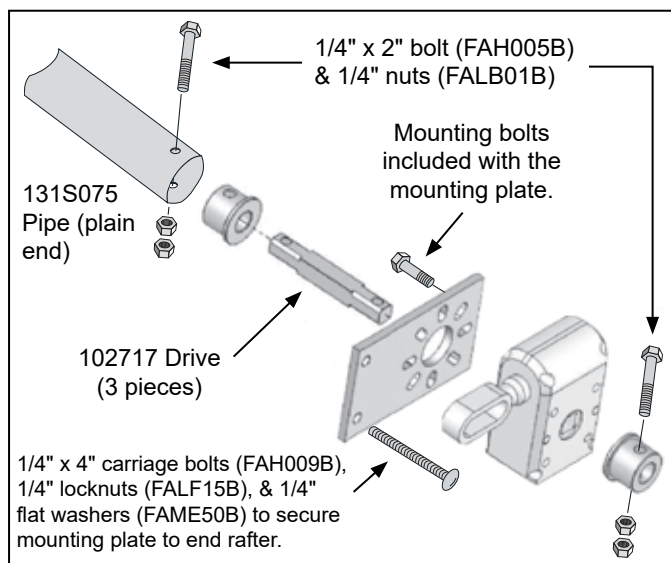

NOTE: Attach the plain end of the 131S075 pipe to the 102717 drive hub. Actual components may differ slightly from those shown in the diagrams.

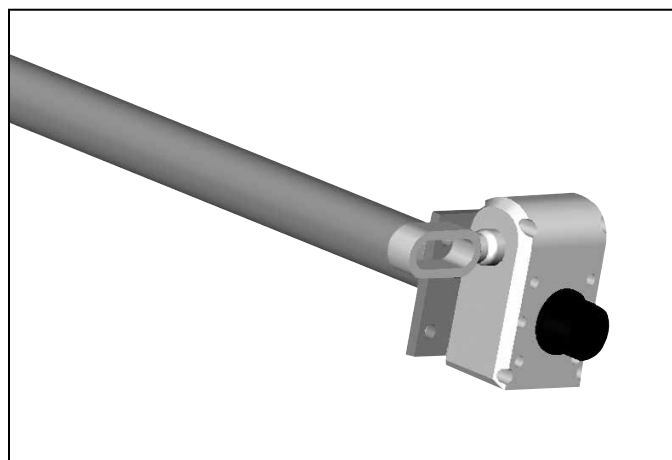
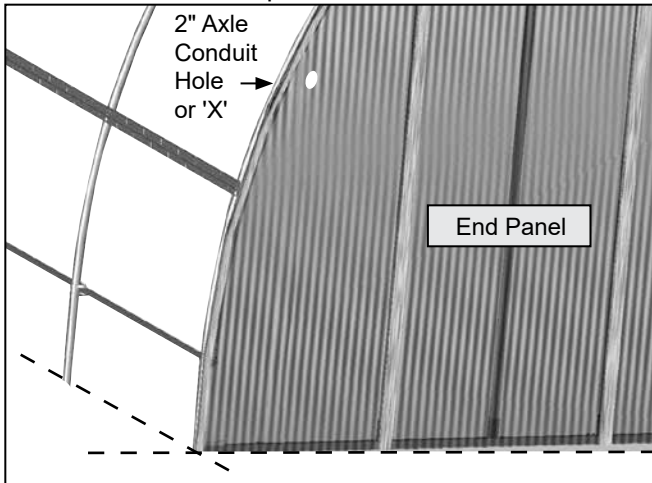

Diagram shows the assembled components.

GROWSPAN™ GOTHIC PREMIUM HIGH TUNNELS

INSTALL THE DROP-DOWN CURTAIN (continued)

10. Carefully lift the assembly and insert the tapered/free end of the 131S075 pipe through the 2" axle conduit hole, or 'X', in the end panel.



11. Align the plate mounting holes with the mounting holes drilled in the end rafter (Step 3) and reattach the mounting plate using two 1/4" x 4" carriage bolts, 1/4" lock nuts, and 1/4" flat washers.

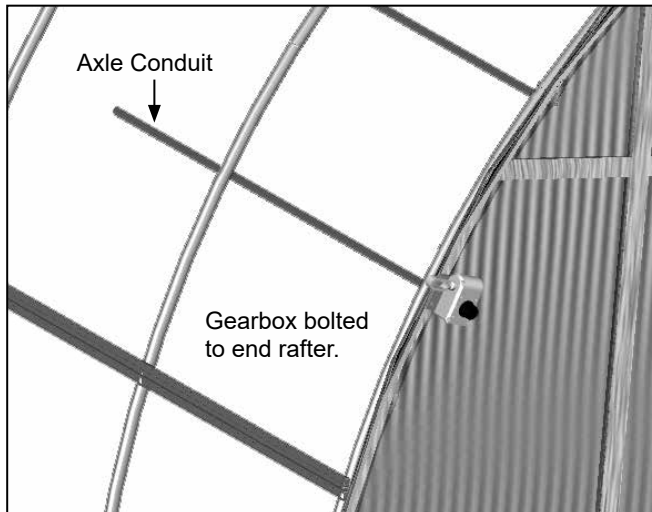

NOTE: Cover is not shown in the above diagram. Diagram shows gearbox mounted to the end rafter on the outside of the end wall cover.

12. Move inside the frame and slide a 106734 band clamp over the tapered end of the 131S075 pipe.

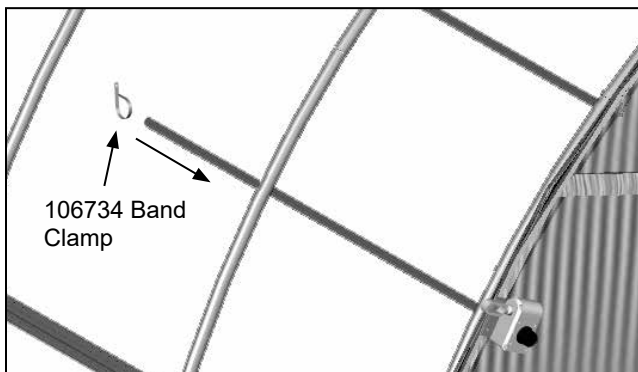

13. Verify that the pipe is level and secure the band clamp to the underside of the second rafter using an FA4482B Tek screw. Pipe should remain loose in the band clamp.

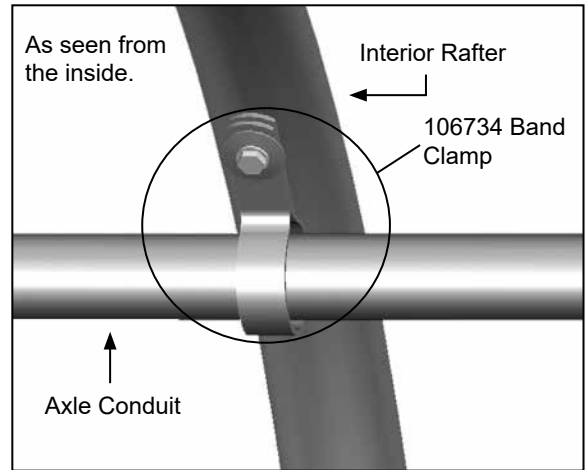

Band clamps support the axle conduit at each rafter except the end rafter where the gearbox is mounted.

14. Take a section of 131S075 pipe, attach it to the first, and secure the connection using one Tek screw.

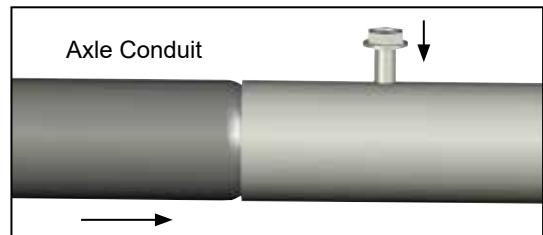

15. Slide another band clamp onto the tapered/swaged end of the conduit, level the conduit, and secure the band clamp to the underside of the next rafter.
16. Continue adding conduit and band clamps and work toward the other end of the shelter. Verify that the axle conduit remains level throughout the length. *Attach one band clamp to the inside of each rafter.*

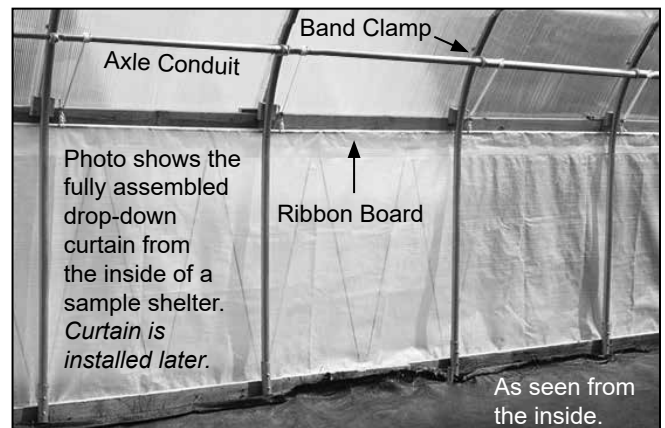

17. Select the final section of plain pipe (131P0XX where XX represents the length needed to reach the end of your building. Consult side profile diagram for pipe identification.)

INSTALL THE DROP-DOWN CURTAIN (continued)

NOTE: To prevent damage to the end panels, *do not allow the free end of the axle to touch the inside surface of the end wall. Trim pipe if needed. Axle must turn freely.*

18. After installing all sections of axle conduit for the first drop-down curtain assembly, verify that the axle conduit is level and that each conduit splice is secured with a Tek screw (see Step 14).
19. Move to the gearbox and test the assembly using the crank handle.

NOTE: The assembled axle conduit should turn freely throughout the length of the shelter. Adjust the band clamps as needed. Reposition clamps and screws if these prevent smooth operation of the axle conduit.

20. After verifying that the axle turns smoothly, repeat the procedure to assemble and attach the gearbox and axle conduit *to the other side of the shelter.*
21. Continue by preparing and attaching the drop-down curtains to the frame and axle conduit of both drop-down assemblies.

Locate these parts to prepare the drop-down curtain for installation and to attach it to the axle conduit:

- 106816 (1/2" pipe conduit)
- CC5505 (1/8" curtain cord)
- FA1960 (3/16" x 3" eye screw)
- AS5020 pulleys
- Duct tape
- Drop-down curtain (Panel ID begins with DD.)

Attach Drop-Down Curtain Pulleys

Continue with the steps that follow:

1. Gather the pulleys and the same quantity of 3" eye screws (FA1960) and move to the inside of the shelter.
2. Slide one pulley onto the threaded shaft of the eye screw and twist the eye screw into the ribbon board 4"-6" on either side of the first rafter to secure the pulley.



NOTE: Position the eye screw and pulley a 4-6 inches away from the rafter on either side of the rafter.

Pulley should hang freely from the eye screw. *Do not overtighten the screw.*

3. Move to the next rafter and repeat the steps to install another pulley. *Install one pulley for each rafter along each side of the frame.*
4. Continue installing eye screws and pulleys into the ribbon board *next to each rafter* until all pulleys are installed *along both sides of the shelter.*
5. Install the curtain conduit and attach cords as described in the next procedure.

GROWSPAN™ GOTHIC PREMIUM HIGH TUNNELS

INSTALL THE DROP-DOWN CURTAIN (continued)

Install Curtain Conduit and Attach Rope

After installing all eye screws and pulleys, locate the drop-down curtain panels, 1/2" conduit (106816), 1/8" rope (CC5505), FA4652 screws, and duct tape. Refer to the parts list on the previous page if needed.

Complete these steps:

1. Unfold the curtain panel along one side of the shelter and position the conduit pocket along the baseboard.

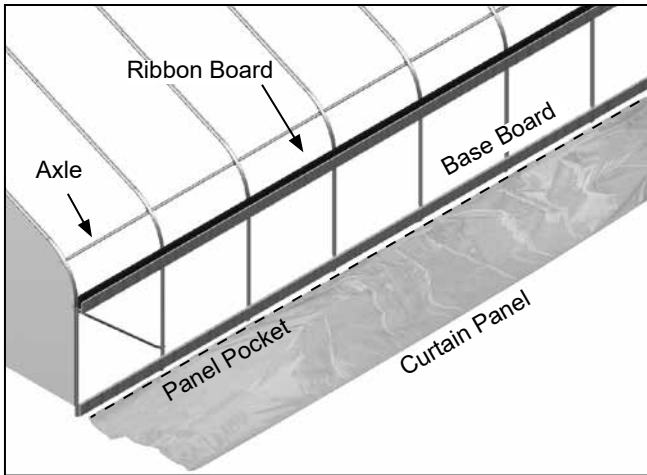

Dashed line shows where to position the pocket of the curtain panel.

2. Take one 8' section of the 1/2" curtain conduit (106816) and insert the plain end (not the tapered end) into the curtain pocket.



Tapered/Swaged End

3. With the first conduit section in the pocket, add another 8' section to the first (plain end over tapered/swaged end) and tape the conduit joint using duct tape.

4. Continue adding conduit sections and taping each joint until the conduit is as long as the curtain panel.
5. Complete the curtain conduit installation by cutting the conduit so that it extends from the panel pocket approximately 1" at each end.

ATTENTION: Depending on the length of the building and the pipe material sent, you may not need to trim the length of the drop-down panel conduit.

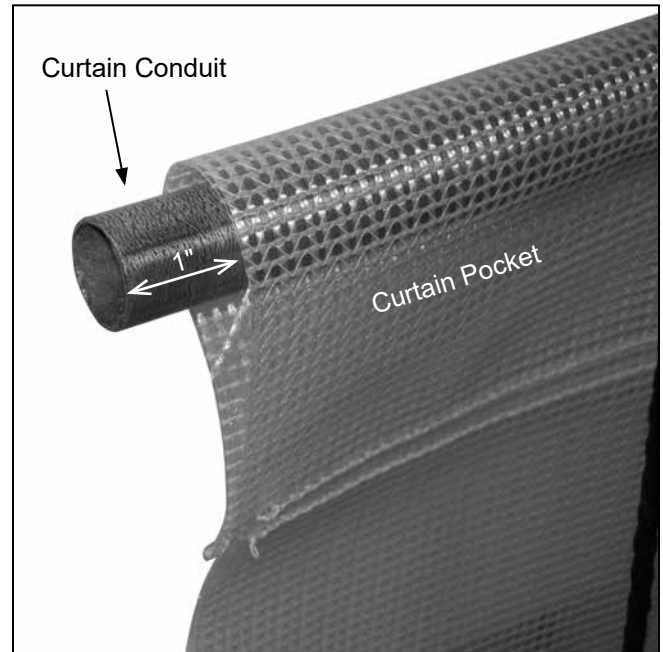

6. Align the curtain and the installed curtain conduit with the end rafters of the shelter.
7. Position the curtain conduit at the base of the baseboard along the outside of the frame.
8. Measure the distance *from the curtain conduit up to the axle conduit* mounted to the frame and add 12" to ensure that the chord length is sufficient.

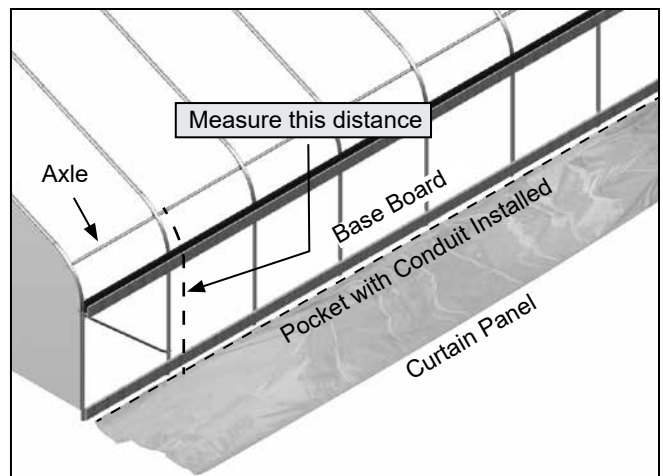
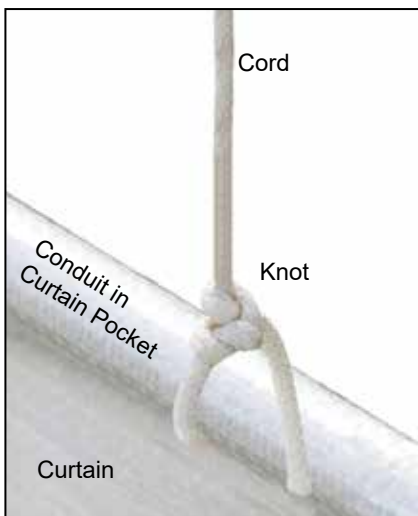

Diagram above shows where to measure to determine cord length.

INSTALL THE DROP-DOWN CURTAIN (continued)

9. Locate the 1/8" curtain cord (CC5505) and cut a section of cord to the length determined in the previous step.
10. Beginning at one end of the frame, move to the curtain conduit in the curtain pocket, and make a small cut in the material *below* the conduit and in line with a pulley.
11. Insert the end of the cord through the opening in the curtain panel and tie the cord to the conduit.



12. Take the free end of the cord, thread it through the pulley, *wrap it over and around the axle conduit*, and temporarily tie it to the axle conduit.

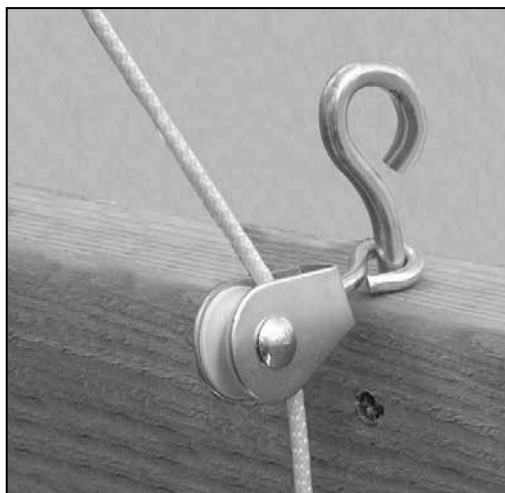

NOTE: Verify that the cord is properly aligned with the pulley and with the other end of the cord tied to the curtain conduit.

The cord must remain aligned for proper curtain operation.

13. Drive two (2) FA4482 Tek screws with neo-bonded washers (102921) into the axle conduit where the cord is located. *Do not fully seat the Tek screws to the conduit.* Allow space to remain between the washer and conduit.

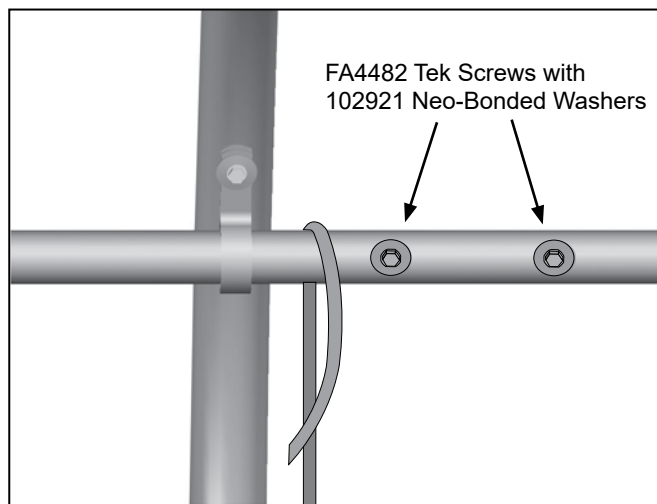

14. Verify that the curtain conduit remains against the baseboard and pull the slack from the cord.
15. Weave the cord around the Tek screws as shown and tighten the screws to secure the cord to the axle.

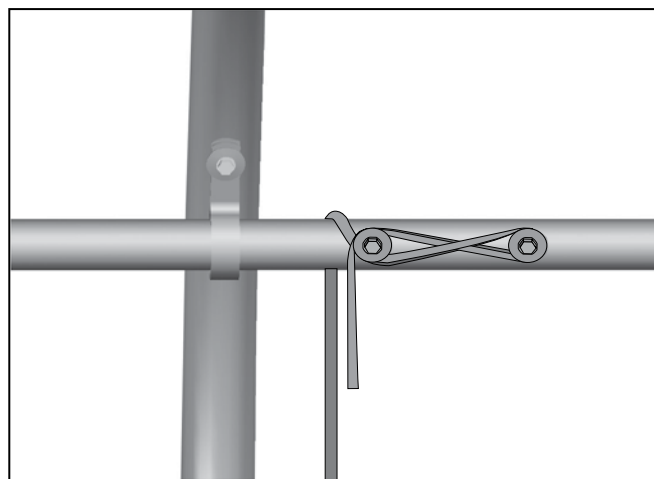

16. Move to the next pulley position and repeat the steps to measure, cut, and attach another cord to the curtain and axle conduit.

ATTENTION: If the cord length was correct for the first, cut additional cords to the same length. To ensure that the curtain remains level during operation, verify that additional cords are wrapped around the axle conduit in the same direction as the first cord. Continue this pattern for all remaining cord-to-axle connections.

GROWSPAN™ GOTHIC PREMIUM HIGH TUNNELS

INSTALL THE DROP-DOWN CURTAIN (continued)

17. Repeat the above steps until all cords are attached to the first curtain panel along one side of the shelter.

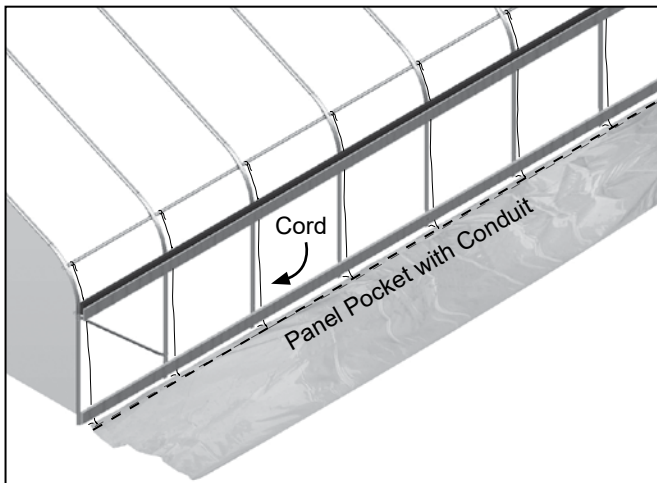

Diagram shows cords attached to the curtain conduit and to the axle. Dashed line shows the position of the curtain conduit.

18. Continue by attaching the lower curtain edge to the baseboard for the first curtain installation.

Attach Lower Edge of the Curtain to Baseboard

After tying all cords to the curtain and axle conduits for the first curtain assembly, secure the free edge (bottom) of the curtain panel to the baseboard.

Use customer-supplied dimension lumber as a retaining board for the lower edge of the curtain. The retaining board must be at least 1" x 2" to adequately secure the curtain to the baseboard. See the diagram below for an example.

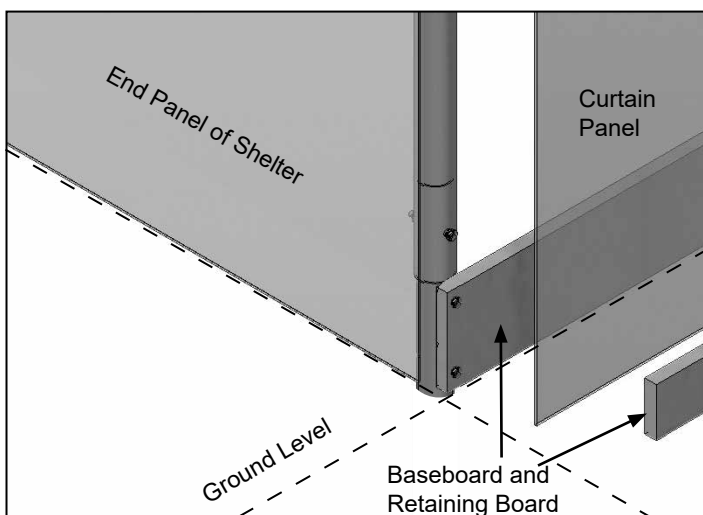
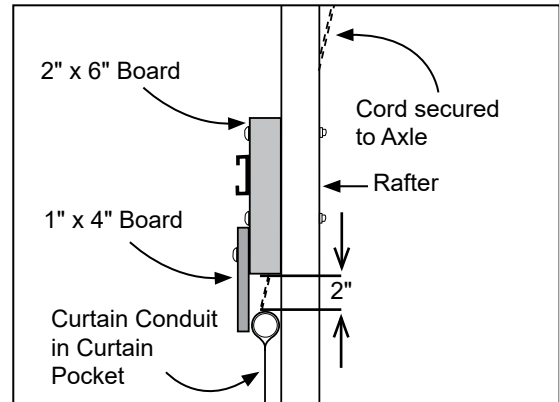

Diagram may show a different frame and curtain assembly.

Complete these steps to attach the lower edge of the curtain to the customer-supplied baseboard.

CAUTION: Do not attempt to attach the curtain to the baseboard during stormy or windy conditions or when such conditions are expected.

1. Using the supplied-crank handle, roll the curtain panel up to within 2" of where it will seat into the channel created by the ribbon boards.



2. Move to the bottom of the panel and with assistance, evenly stretch the panel end-to-end along the baseboard.

3. Take the first section of customer-supplied retaining board and place it against the curtain and the baseboard to hold the curtain in position.

NOTE: Evenly and gently pull the curtain edge down to remove wrinkles. *Applying too much force will bend the curtain conduit.*

4. Using the supplied FA4652 fasteners, secure the retaining board to the baseboard as shown.

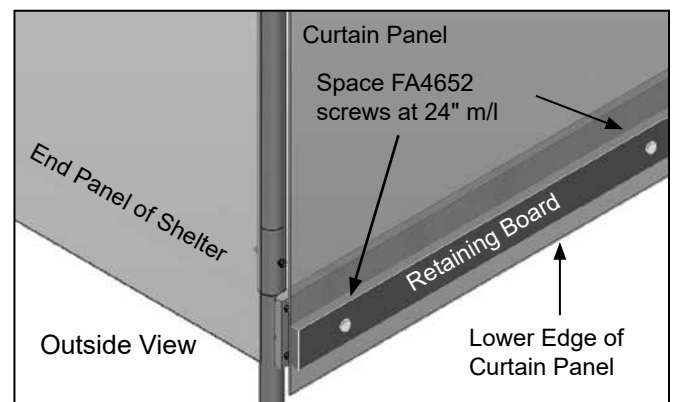

5. Repeat the steps to secure the remaining lower edge of the curtain to the baseboard along the side.

6. Return to the gearbox and check the operation of the drop-down curtain panel using the crank handle. Adjust cords as needed for a level curtain.

7. Repeat the steps to attach the remaining curtain to the other side of the building.

8. Install the anti-billow rope.

Install the Anti-Billow Ropes

The anti-billow ropes keep the drop-down curtain in place when it is fully or partially open. Using the diagrams below, complete the anti-billow rope installation.

ATTENTION: INSTALL THE ANTI-BILLOW ROPE IN SHORT SECTIONS ALONG EACH SIDE TO KEEP THE CURTAIN SECURE IN CASE ONE ROPE BREAKS.

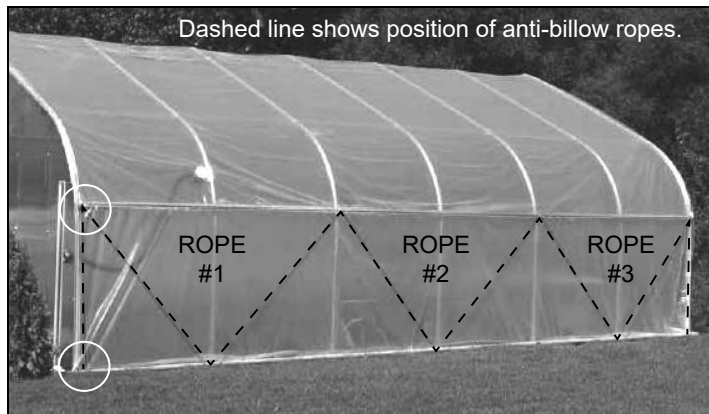

1. Beginning at *one end rafter*, take two (2) eye screws and align and attach one to the baseboard and one to the ribbon board.

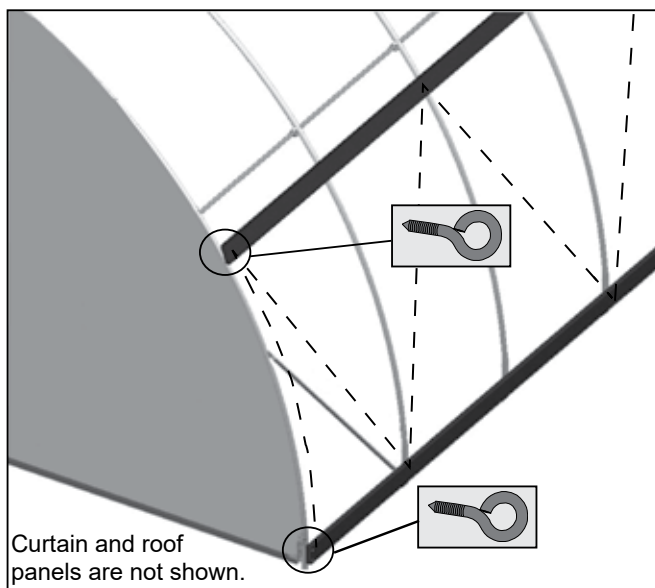

2. Using the sample diagrams as guides, move to the next rafter and attach the eye screw to either the baseboard or the ribbon board, depending on the pattern.
3. Continue installing the eye screws until you reach the other end rafter and finish the installation by repeating Step 1. Install eye screws for the remaining side.
4. Install the anti-billow rope **in short lengths along each side**. Thread the free end of the rope through the end rafter eye screws and through the eye screws at two to three interior rafters. Cut the rope and tie the ends to the eye screws.
5. Repeat this pattern of **installing short rope lengths** for the remainder of the first side and the other side.

INSTALL ROLL-UP DOOR PANEL ROPES

The roll-up panel ropes are laced through the roll-up panel. These ropes wrap around hook lags that are screwed into the sides of the door frame. When installed correctly, these ropes help to keep the roll-up panel in place when it is fully or partially closed. These steps describe one way to lace the roll-up panel.

Gather the parts:

- Hook lags (#FAX120)
- Rope (#CC5505)
- Zipper extension pole (#CC2235)

1. Beginning on the *outside of a door frame*, attach a hook lag between the first two grommet holes below the bracket. Position the open end of the hook lag towards the end panel.

IMPORTANT: Screw hook lags into the sides of the door frame, not the front. *Do not screw into the roll-up panel.*

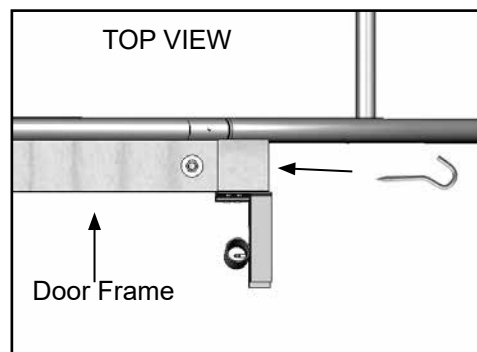
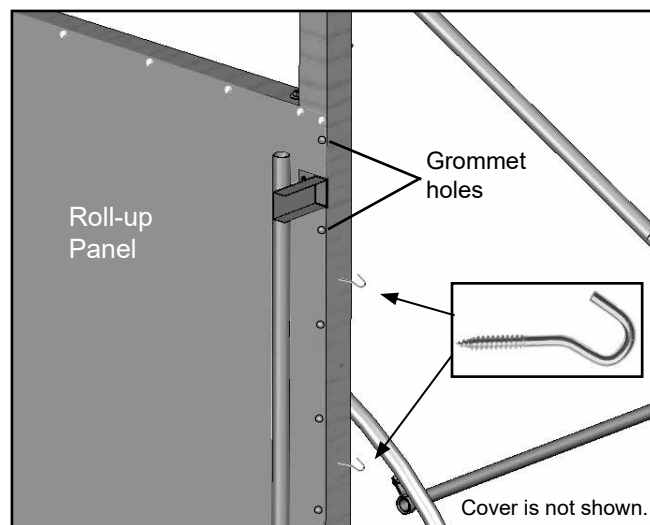

Photo shows the open end of the hook lag facing the end panels.

2. Install a hook lag at every other grommet interval as shown in the diagram below. Use five (5) hooks for each side.



GROWSPAN™ GOTHIC PREMIUM HIGH TUNNELS

INSTALL ROLL-UP PANEL ROPES (continued)

3. Tie a length of rope to the first grommet hole below the guide post bracket, loop it around the first hook lag, and lace it back through the next grommet. Repeat this process until the rope is through the last grommet.

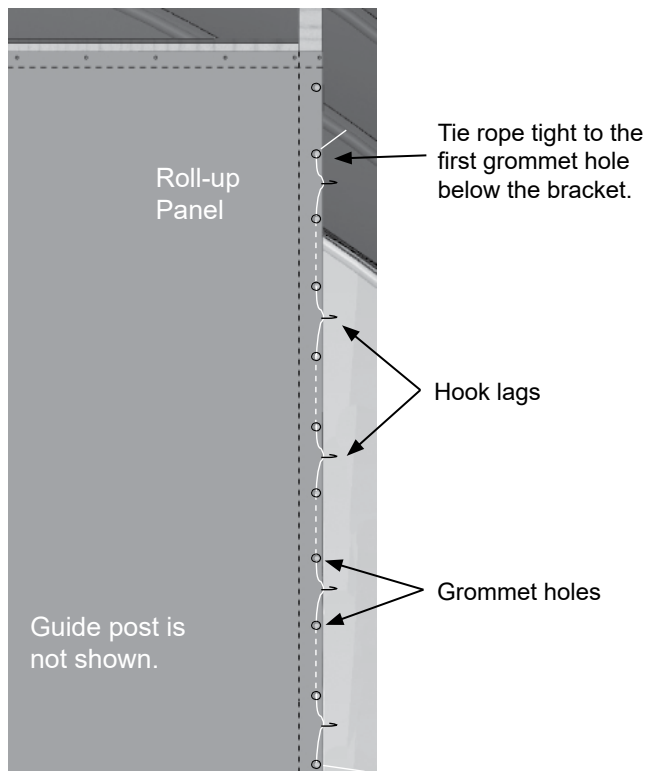

White dashed line shows the rope laced behind the roll-up panel.

4. Leaving some slack, loosely tie the rope off at the bottom grommet hole.
5. Repeat steps 1 through 4 for the other side of the door frame.
6. Once the ropes on both sides are laced and hooked in the correct position, untie the rope at the bottom grommet holes, pull tight to remove excess slack, and tie off at the bottom grommet holes.
7. Repeat for the remaining end.

NOTE: Use the included zipper extension pole (CC2235) to unhook the rope to open the roll-up panel. The pole can also be used to loop the rope back onto the hook lags when the roll-up panel is closed.

8. Read the **Install the Wind Panel** information that follows.

INSTALL THE WIND PANEL ACCESSORY (OPTIONAL)

BUILDINGS WITH DROP-DOWN SIDES: Wind panels protect drop-down curtain at each corner of shelter. When installed, these panels allow wind to flow over corners and around the shelter and help keep the drop-down curtain in position. **Installation is optional but recommended.**

BUILDINGS WITH ROLL-UP SIDES: Wind panels are not typically used for roll-up sides as they would hamper the operation of the panels. However, the **D10025824M** material can be used to winterize the corners when the growing season is over or temperatures drop.

The following wind panel items are included with shelter:

- Wind Panel Material: (6' x 8' panel)—D10025824M
- Tek screws (FA4482B), wood screws (FA4652B), and neo-bonded washers (102921B)

The procedure that follows describes one way to install the wind panels using Tek screws, wood screws, and neo-bonded washers. Shelter design and other factors may require minor adjustments to these instructions. Fasteners are installed into the end rafter, ribbon boards, and baseboards. *Additional customer-supplied materials may be needed for some custom shelters.*

Complete the following steps to install the wind panel:

1. Place the 6' x 8' wind panel on a flat surface and cut it into four (4) equal 2' x 6' sections.
2. Using the crank assembly, roll the curtain up until it is a few inches below the ribbon board.

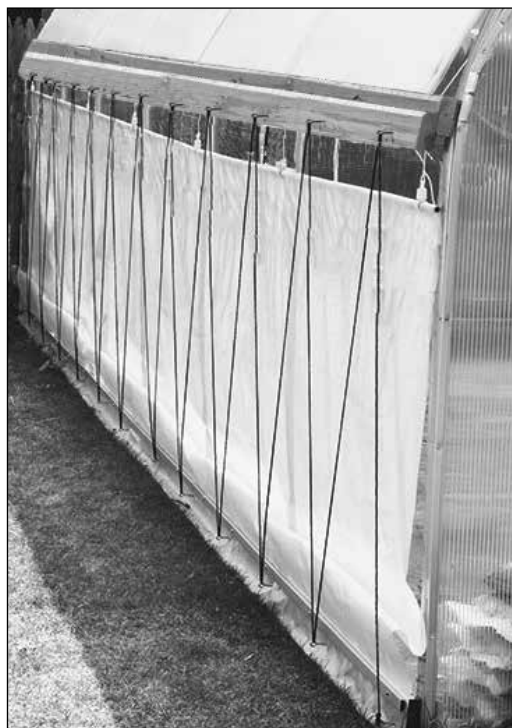

INSTALL THE WIND PANEL ACCESSORY (continued)

- Place a 2' x 6' wind panel over the end of the drop-down curtain at one corner of the shelter and align it with the end rafter as shown below.
- Using wood screws and washers, secure the top of the wind panel to the ribbon board. Space the screws every 12" along the top of the panel.

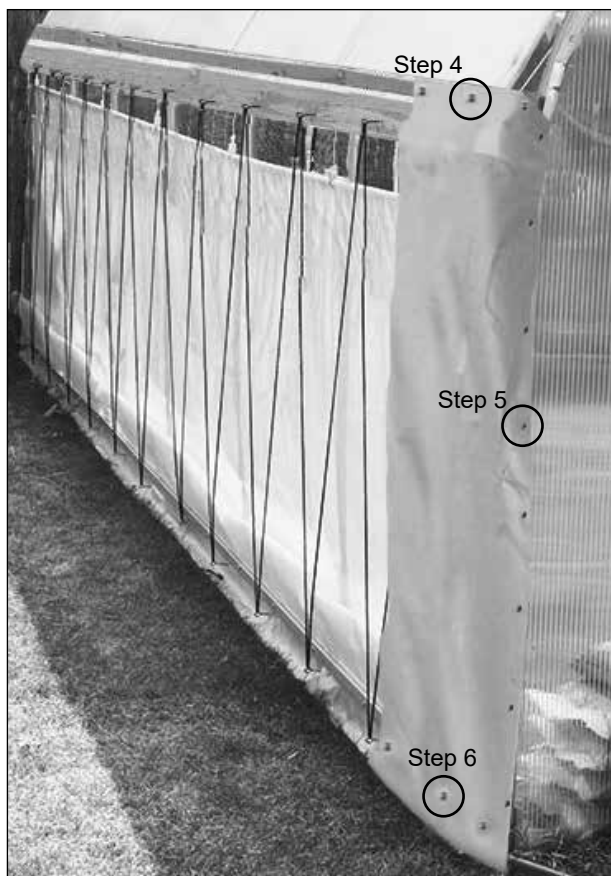

- With the panel secured at the top, fold the panel edge around and attach the panel to the end rafter using Tek screws and washer. Space the Tek screws every 6-8 inches.
- Secure the bottom of the panel to the baseboard using wood screws and washers.

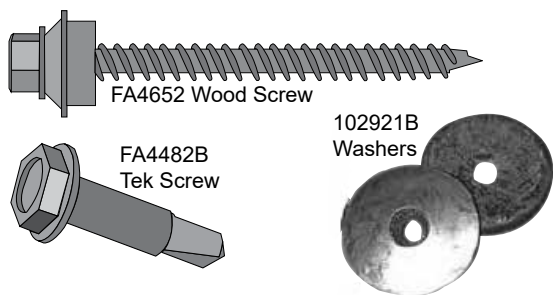

NOTE: If needed, trim excess material along the edge of the end wall. Drawings are not to scale.

- Continue as instructed in the following procedure.

INSTALL THE RIDGE VENT COVER

If you purchased the ridge vent kit for your FD model, continue with the steps below to complete the cover installation for the kit. **Skip this section if you did not purchase the additional ridge vent kit.**

Gather the parts:

- Cover and ratchets (#QH1061)
- Customer-supplied fasteners: *Due to the different materials used for the ribbon board, the customer is responsible for supplying the required fasteners. Consult the advice of a qualified professional contractor if needed.*

WARNING: To prevent damage and injury, do not leave the cover unattended if it has not been properly secured.

Complete the following steps to install the ridge vent cover.

- Set ridge vent cover on top of shelter, center the cover, and unfold in both directions toward the ribbon board attached along the sides of the frame.
- Using the cover straps as a guide, attach two (2) ratchets (#QH1061) to the ribbon board as shown in the diagram below.

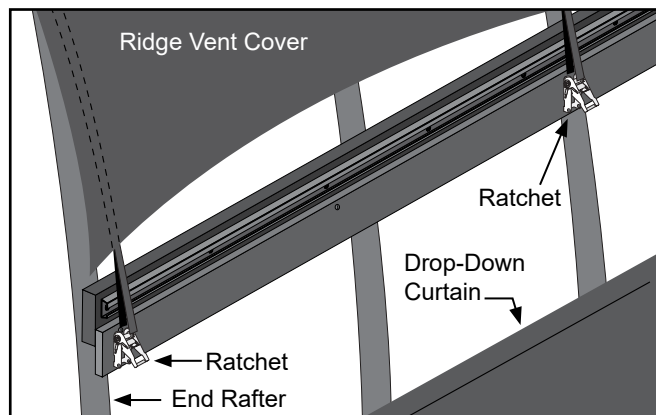

NOTE: The ratchets are attached on the ribbon board below the U-Channel using customer-supplied fasteners.

- Install the remaining two (2) ratchets on the other side of the frame immediately across from the first ratchets installed in Step 2.

Two (2) QH1061 ratchets are used on each side of the shelter to secure one ridge vent cover.

GROWSPAN™ GOTHIC PREMIUM HIGH TUNNELS

INSTALL THE RIDGE VENT COVER (continued)

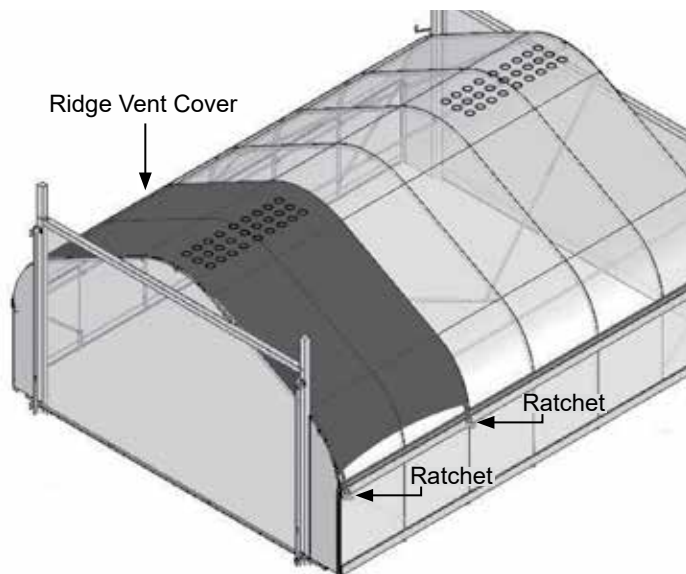

4. With assistants holding the strap ends along one side of the frame, feed the strap ends on the opposite side through the center slot in each ratchet. Operate the ratchet to wrap the strap onto the center hub just enough to keep the strap secure.

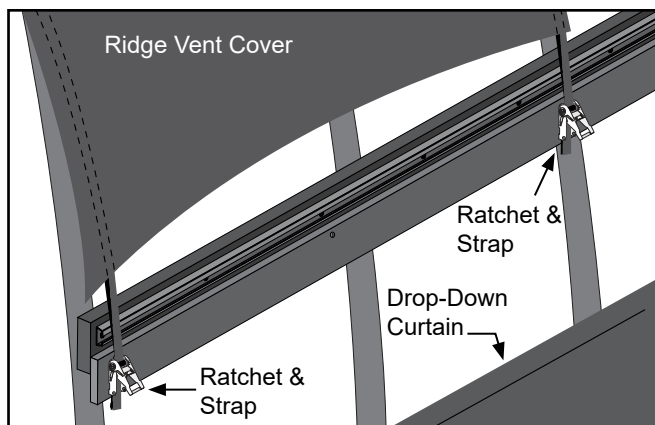

NOTE: Do not tighten completely at this time.

5. Repeat the previous steps to secure the opposite side. Photo above shows an example of a shelter with the ratchets attached and the ridge vent cover secured. *Main cover is not shown.*
6. After all side straps are in place and slightly tightened and the ridge vent cover is centered on the frame, tighten all ratchets evenly.

NOTE: Edge of the vent cover will overlap the second rafter and will be snug against the main cover to keep in place.

7. Repeat steps to install additional ridge vent cover for the remaining end of shelter. (Additional purchase required.)
8. Read the care and maintenance information that follows.

SHELTER CARE AND MAINTENANCE

Proper care and maintenance of the shelter is important. Check the following items periodically to properly maintain the shelter:

- Regularly check the cover or covers to see that these are tight and in proper repair. Tighten and adjust the tension as needed to prevent damage and wear.
- Check connections and all fasteners to verify that they remain tight and in good condition.
- Do not climb or stand on the high tunnel at anytime.
- Inspect the anchoring system to verify that all components remain tight and in good condition.
- Verify that the curtain components are in good working condition.
- Do not allow drop-down curtain to remain in the down position for extended periods. Raise the curtain to allow it to dry and for cleaning.
- Replace cords (used to raise and lower curtain) and anti-billow rope immediately if worn or broken.
- Remove debris and objects that can accumulate on the high tunnel. Use tools that will not damage the cover when removing debris.
- Remove snow to prevent excess accumulation. Use tools that will not damage the cover when removing snow.
- Check the contents of the shelter to verify that nothing is touching the cover that could cause damage.
- If the shelter is dismantled and moved, inspect all parts and connections before using.
- Depending on the contents, construction of the shelter, shelter materials, and shelter location, the potential for condensation exists. GrowSpan™ offers several items that can be used to alleviate a condensation condition. Please contact a GrowSpan™ representative for additional information.
- For replacement or missing parts, call 1-800-245-9881 for assistance.



greenhouse structures

QUICK START GUIDE

20' Gothic Premium High Tunnels

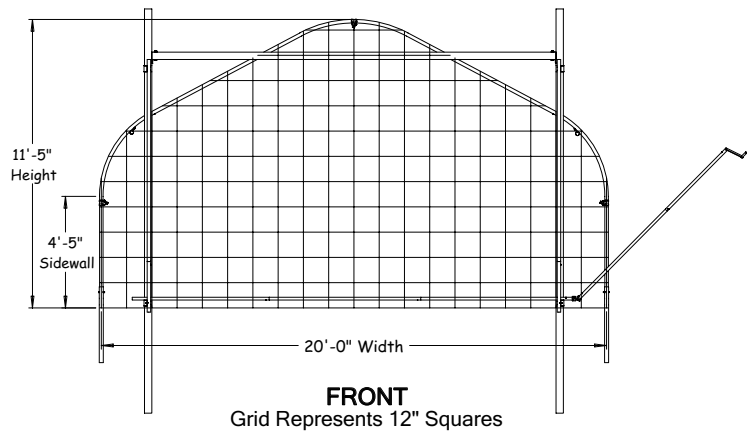

- COVER MATERIAL**
- 6ml FILM FOR CD MODELS
 - 5.2OZ CLEAR FABRIC FOR FD MODELS (QC in material sku#.)

MATERIAL TO COVER END FRAME AND DOOR FRAME AREAS: DCC4931.
See dark shaded areas in diagram.

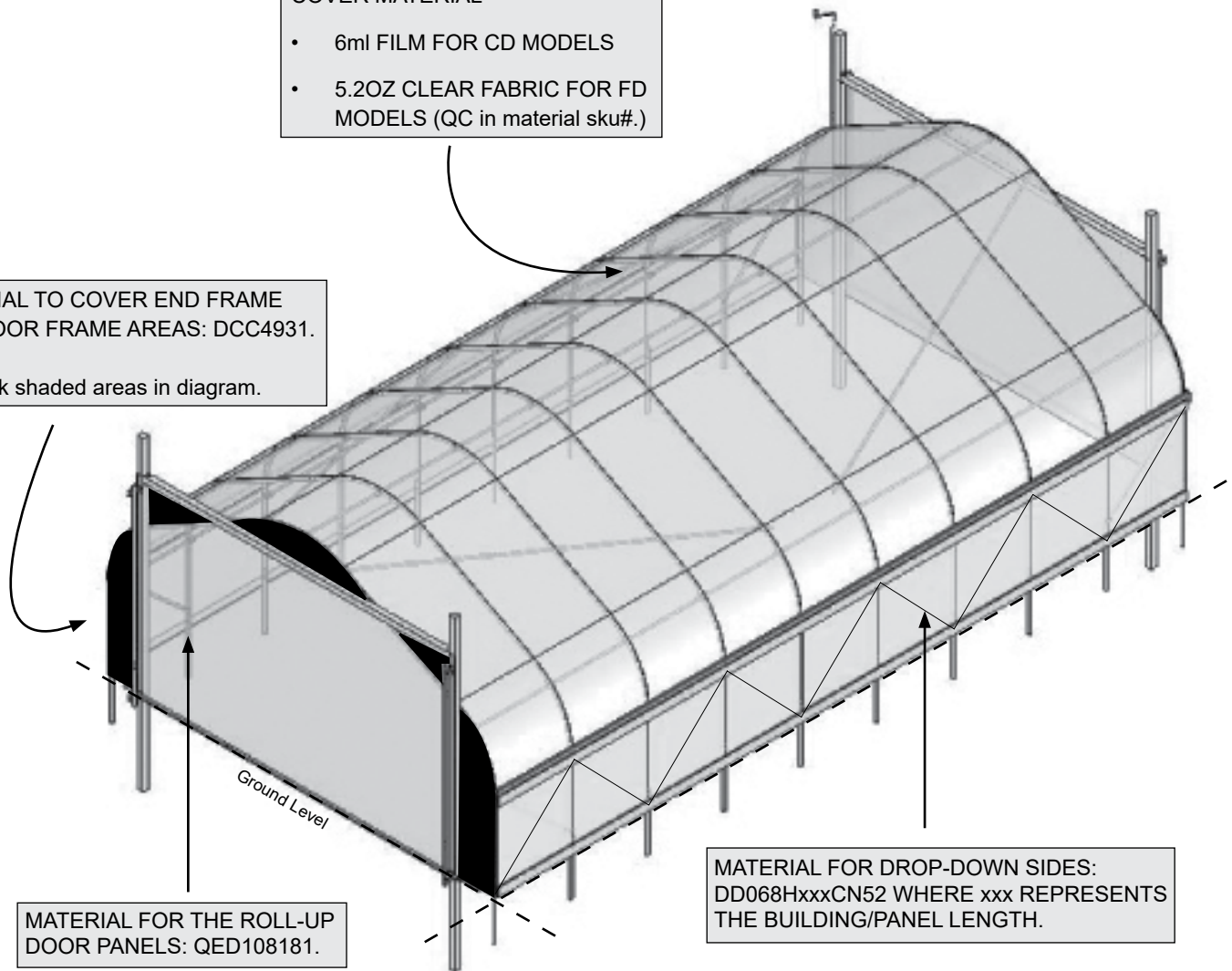

MATERIAL FOR THE ROLL-UP DOOR PANELS: QED108181.

MATERIAL FOR DROP-DOWN SIDES: DD068HxxxCN52 WHERE xxx REPRESENTS THE BUILDING/PANEL LENGTH.

**MATERIAL IDENTIFICATION
DIAGRAM**

Frame shown may differ in length from actual frame.

FRONT PROFILE

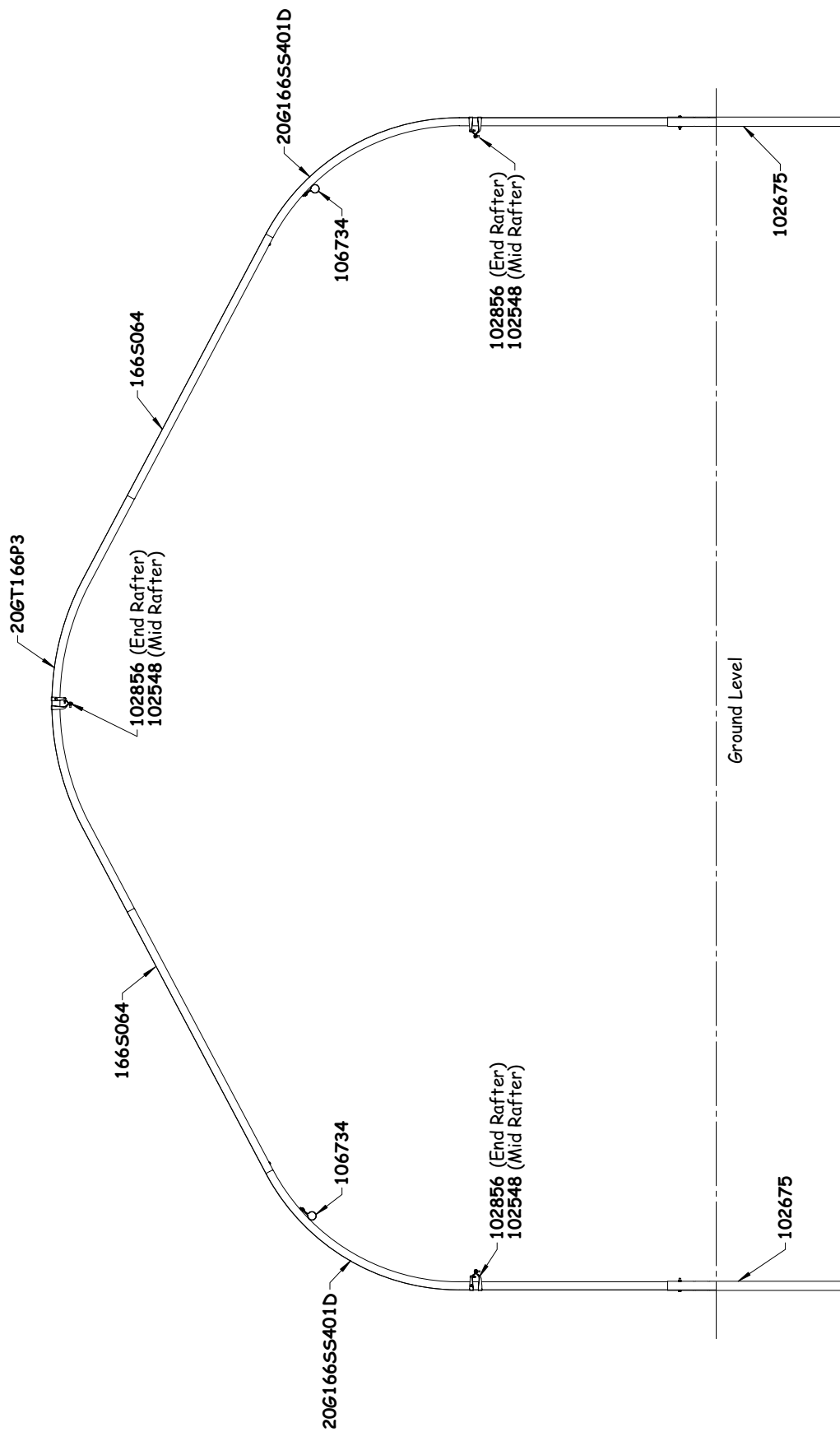

SIDE PROFILE - 108179

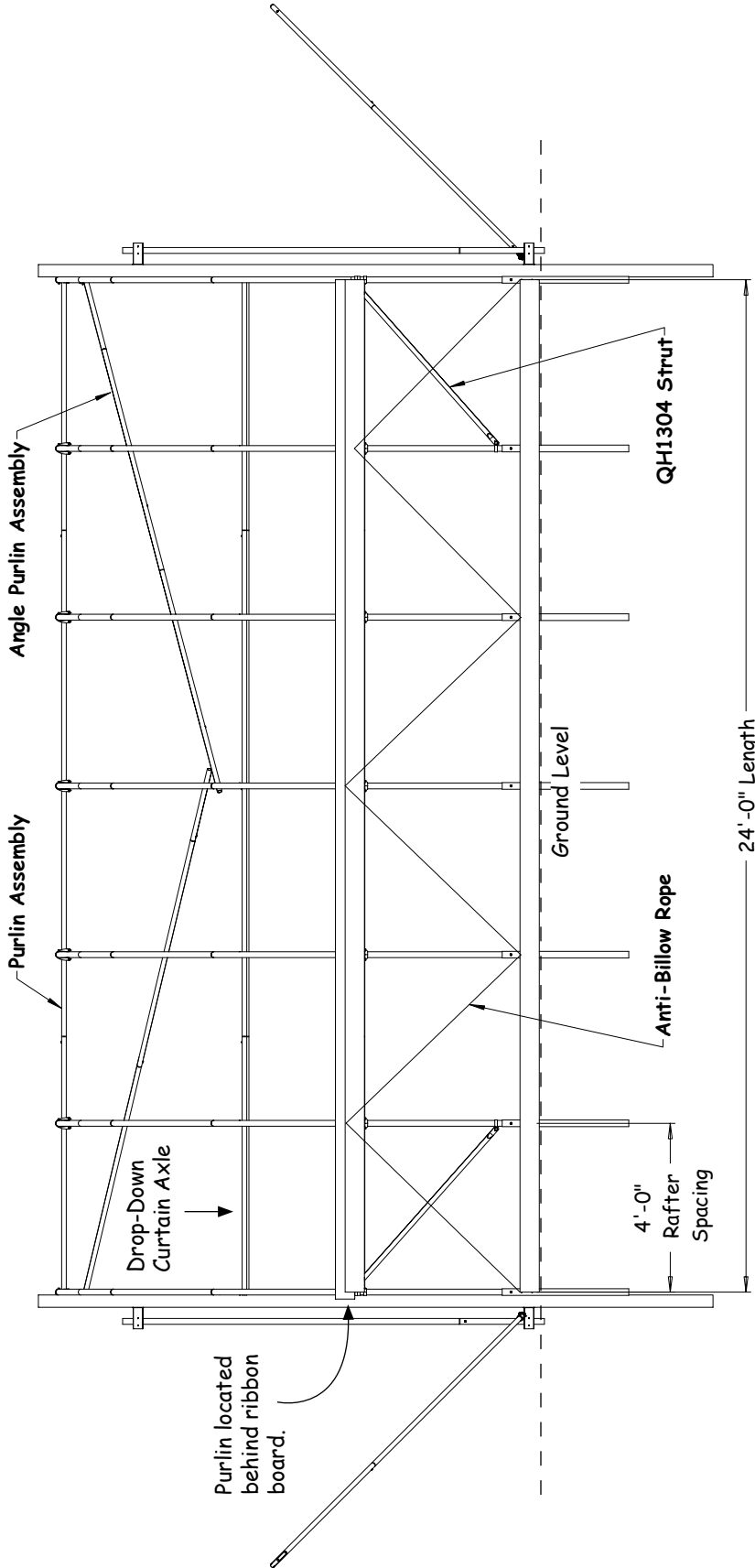

ATTENTION: TO PREVENT DAMAGE AND POSSIBLE INJURY, INSTALL THE ANTI-BILLOW ROPE IN SHORT LENGTHS ALONG EACH SIDE OF THE FRAME. DO NOT INSTALL AS A SINGLE LENGTH TIED AT EACH END. DOING SO WILL RESULT IN A LOOSE SIDE PANEL SHOULD THE ROPE BREAK DURING STRONG WINDS.

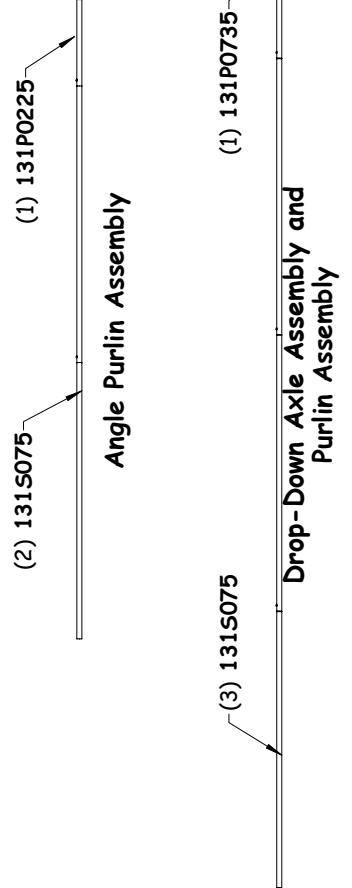

SIDE PROFILE - 108180

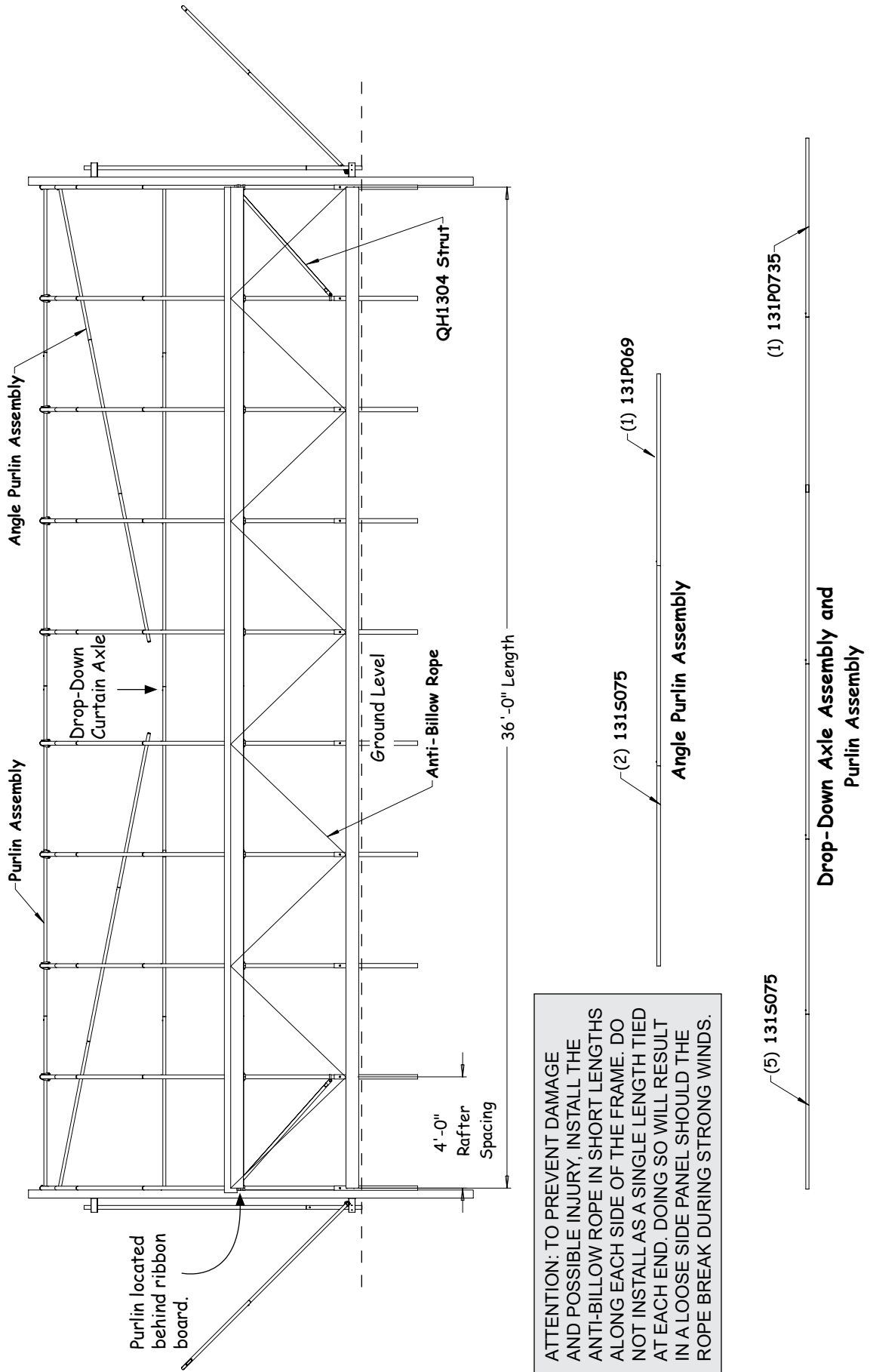

ATTENTION: TO PREVENT DAMAGE AND POSSIBLE INJURY, INSTALL THE ANTI-BILLOW ROPE IN SHORT LENGTHS ALONG EACH SIDE OF THE FRAME. DO NOT INSTALL AS A SINGLE LENGTH TIED AT EACH END. DOING SO WILL RESULT IN A LOOSE SIDE PANEL SHOULD THE ROPE BREAK DURING STRONG WINDS.

SIDE PROFILE - 108181

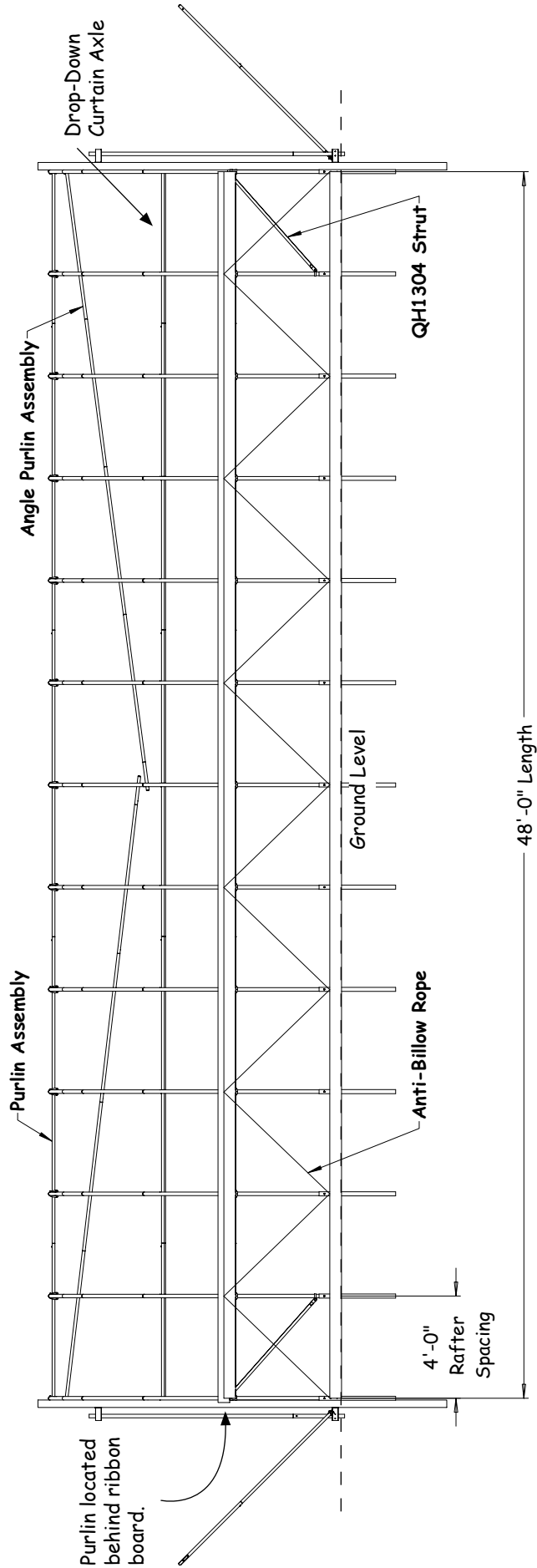

ATTENTION: TO PREVENT DAMAGE AND POSSIBLE INJURY, INSTALL THE ANTI-BILLOW ROPE IN SHORT LENGTHS ALONG EACH SIDE OF THE FRAME. DO NOT INSTALL AS A SINGLE LENGTH TIED AT EACH END. DOING SO WILL RESULT IN A LOOSE SIDE PANEL SHOULD THE ROPE BREAK DURING STRONG WINDS.

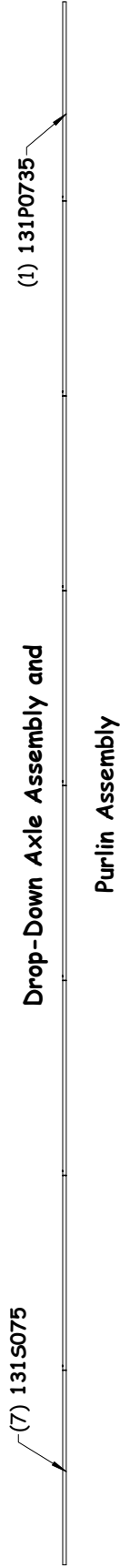
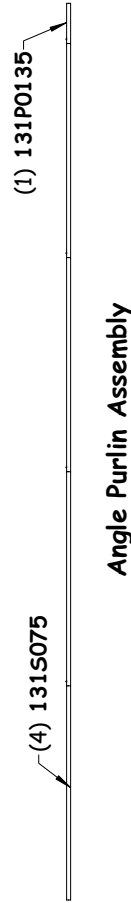

SIDE PROFILE - 108182

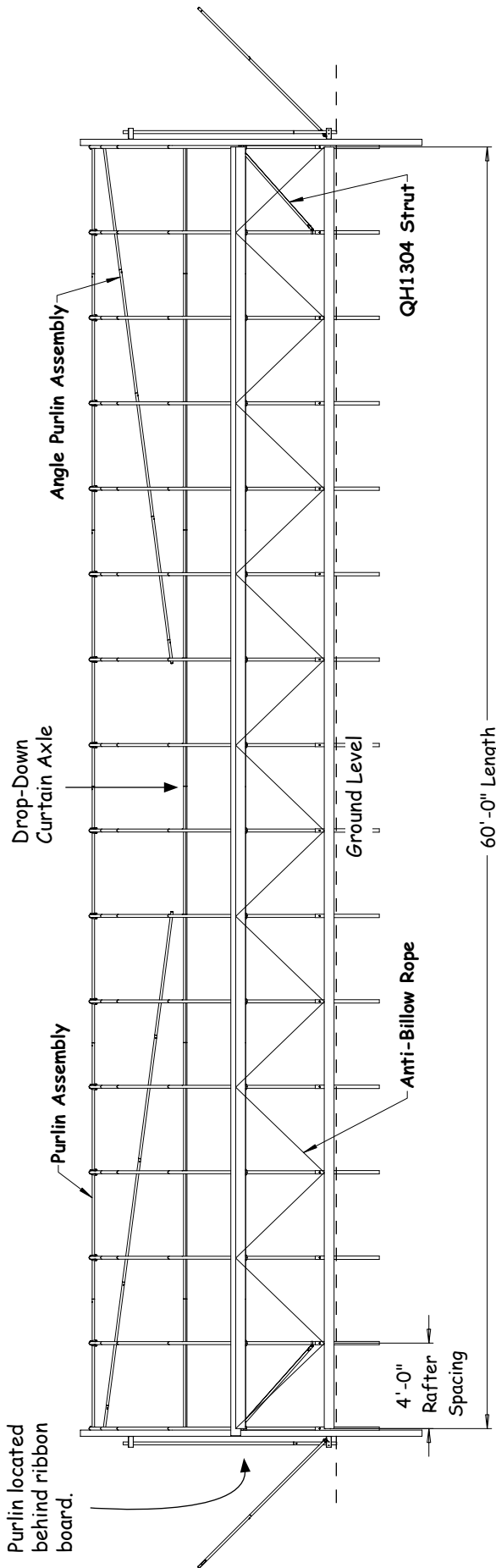

ATTENTION: TO PREVENT DAMAGE AND POSSIBLE INJURY, INSTALL THE ANTI-BILLOW ROPE IN SHORT LENGTHS ALONG EACH SIDE OF THE FRAME. DO NOT INSTALL AS A SINGLE LENGTH TIED AT EACH END. DOING SO WILL RESULT IN A LOOSE SIDE PANEL SHOULD THE ROPE BREAK DURING STRONG WINDS.

(4) 1315075

(1) 131P0135

Angle Purlin Assembly

(9) 1315075

Drop-Down Axle Assembly and

(1) 131P0735

Purlin Assembly

SIDE PROFILE - 108183

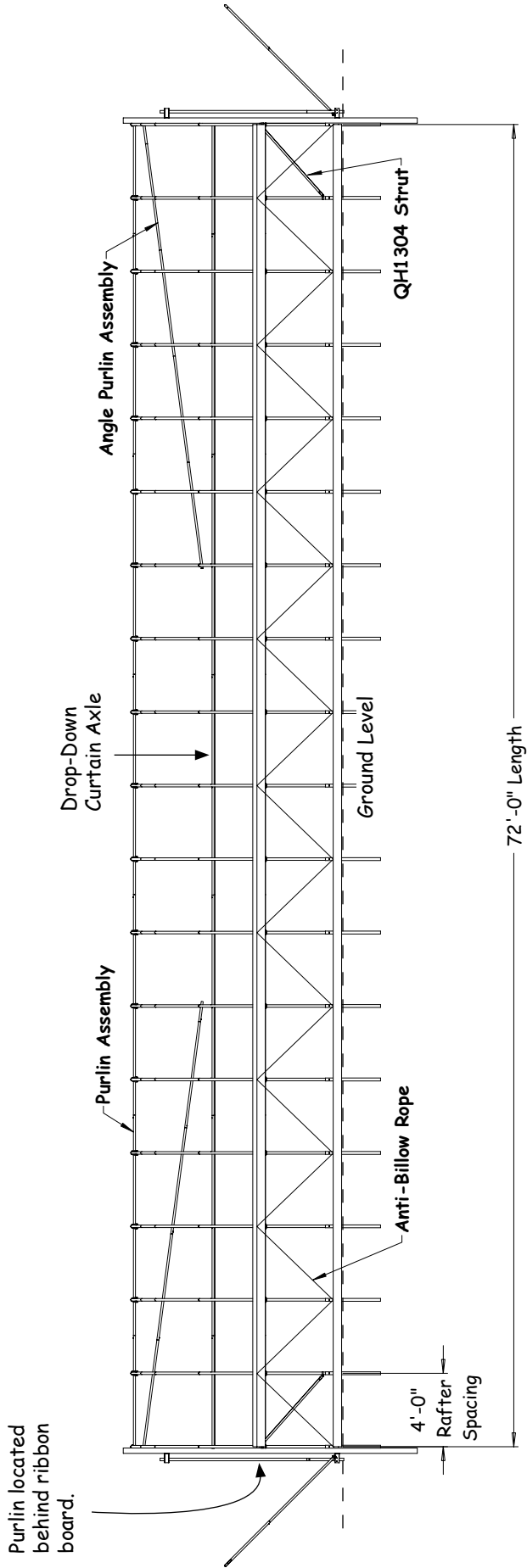

ATTENTION: TO PREVENT DAMAGE AND POSSIBLE INJURY, INSTALL THE ANTI-BILLOW ROPE IN SHORT LENGTHS ALONG EACH SIDE OF THE FRAME. DO NOT INSTALL AS A SINGLE LENGTH TIED AT EACH END. DOING SO WILL RESULT IN A LOOSE SIDE PANEL SHOULD THE ROPE BREAK DURING STRONG WINDS.

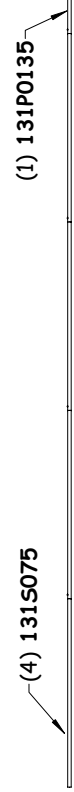

Angle Purlin Assembly



Drop-Down Axle Assembly and Purlin Assembly

SIDE PROFILE - 108184

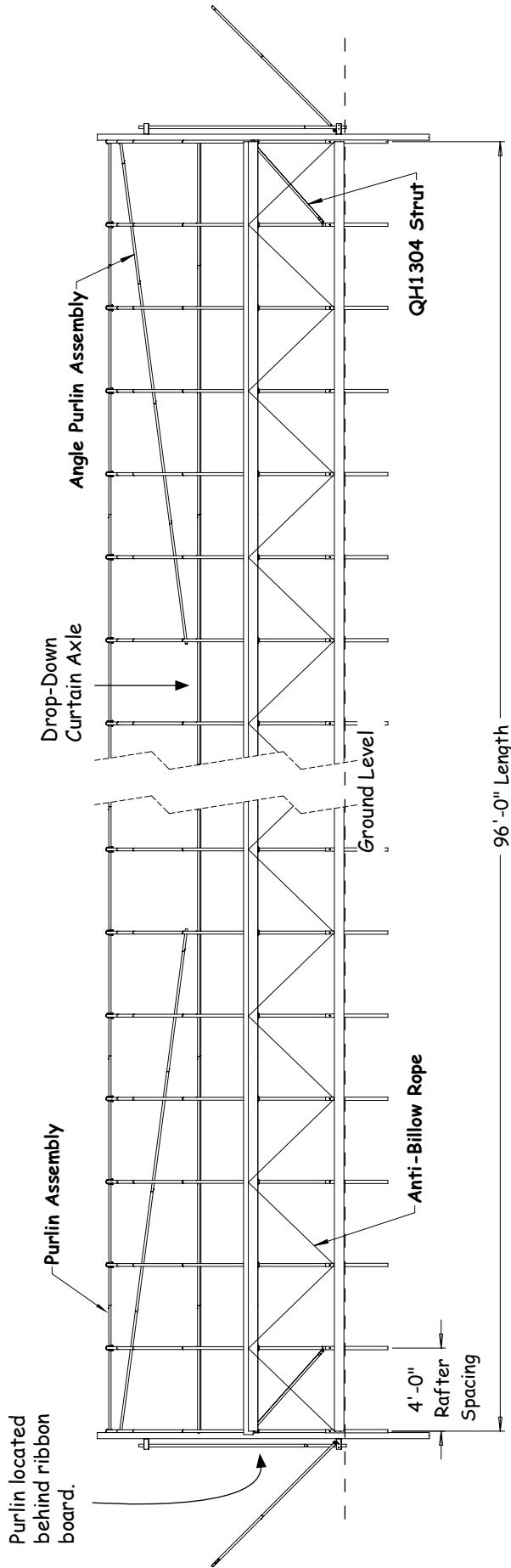

ATTENTION: TO PREVENT DAMAGE AND POSSIBLE INJURY, INSTALL THE ANTI-BILLOW ROPE IN SHORT LENGTHS ALONG EACH SIDE OF THE FRAME. DO NOT INSTALL AS A SINGLE LENGTH TIED AT EACH END. DOING SO WILL RESULT IN A LOOSE SIDE PANEL SHOULD THE ROPE BREAK DURING STRONG WINDS.

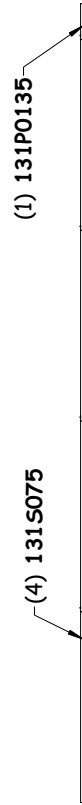

Angle Purlin Assembly

(15) 131S075

(1) 131P0735

Drop-Down Axle Assembly and Purlin Assembly

CONNECTIONS

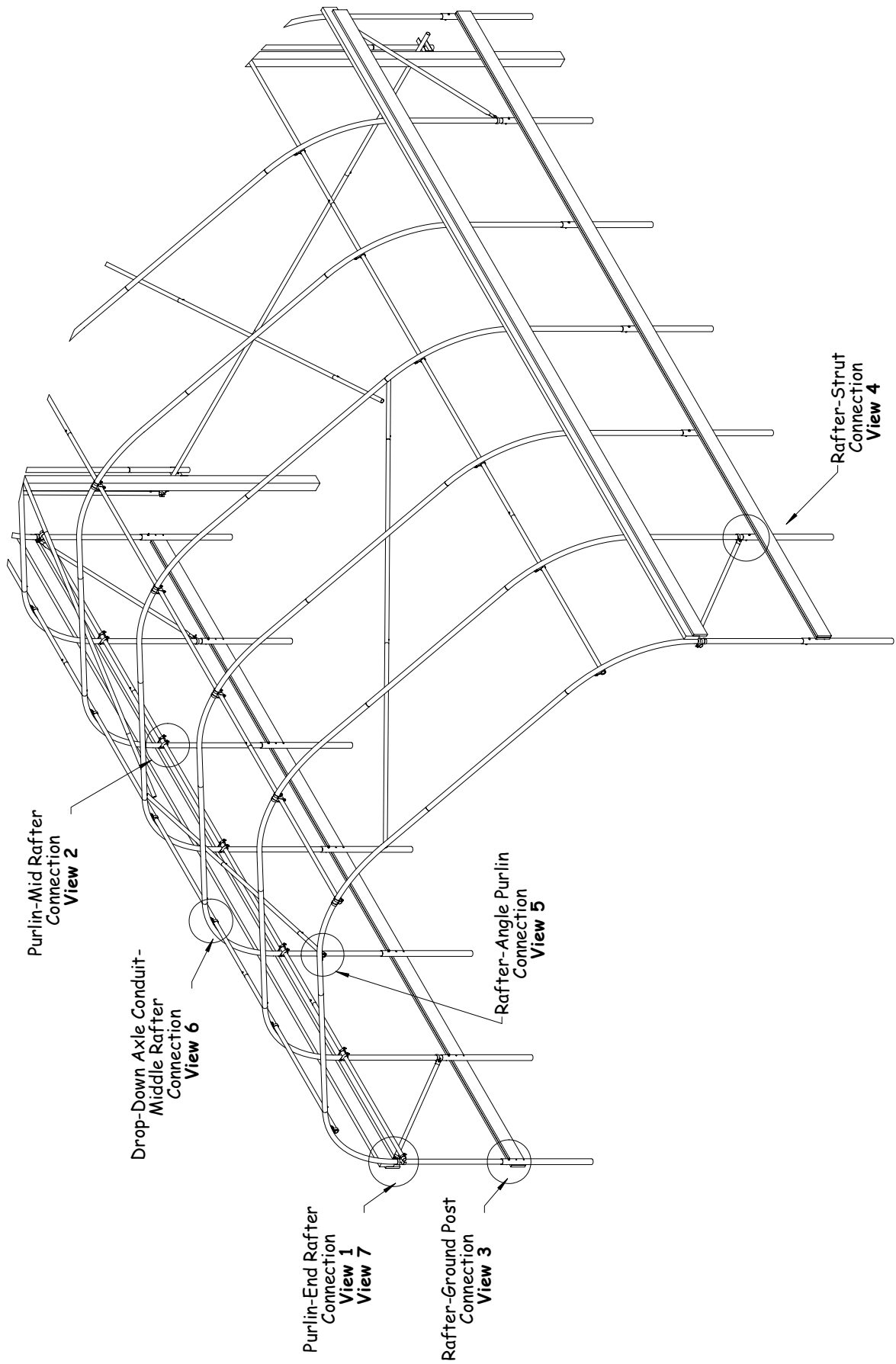

CONNECTION - DETAILS

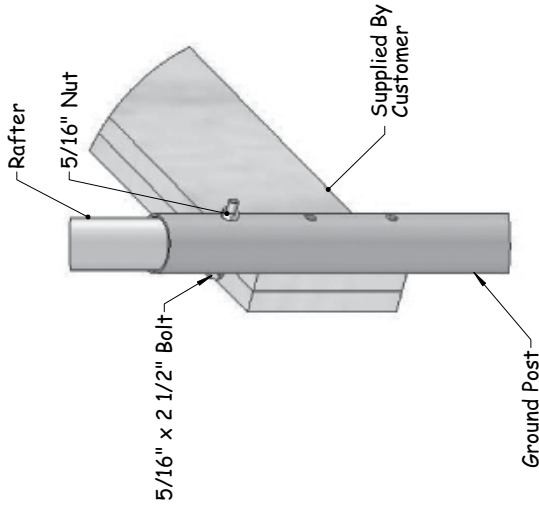

View 3
Rafter-Ground Post Connection

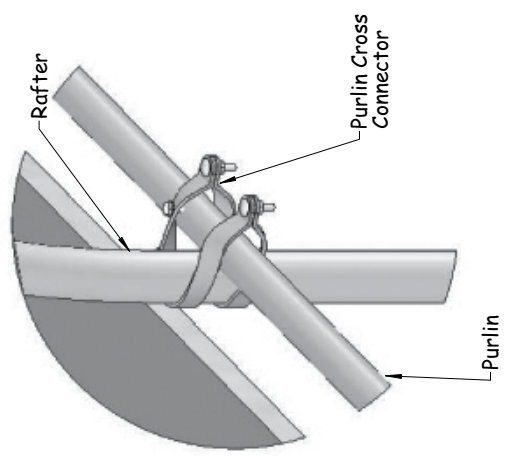

View 2
Purlin-Mid Rafter Connection

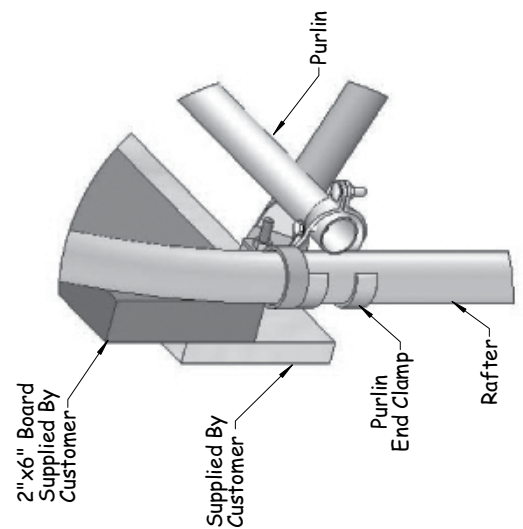

View 1
Purlin-End Rafter Connection

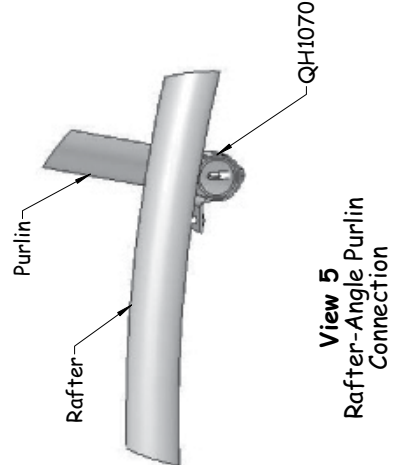

View 5
Rafter-Angle Purlin Connection

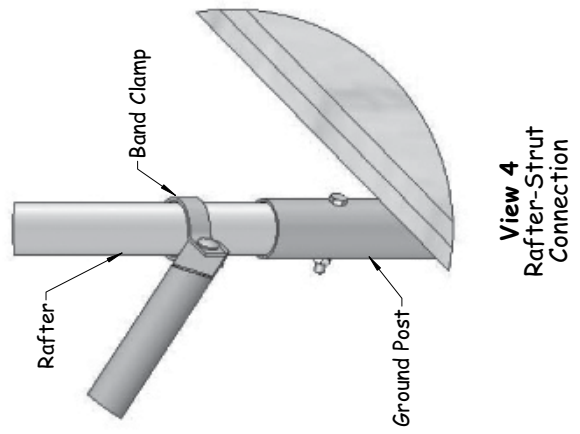

View 4
Rafter-Strut Connection

END FRAMING

ATTENTION: Construct the end wall frame as shown with the vertical jambs extending above the header 18" to 24". This provides an anchor point for cables if you decide to install them now or in the future.

CUSTOMER-SUPPLIED END FRAME: Construct the end frame for the roll-up end panel using 4" x 4" wood posts. The door frame materials are supplied by the customer. If quality 4" x 4" lumber at the lengths needed is not available, construct 2-ply wood beams using 2" x 6" boards secured together with exterior grade bolts and nuts. Center the doorframe in the end wall and dig the holes for the doorjamb.

Stagger all joints. Do not align. Use treated lumber and set in concrete for best results.

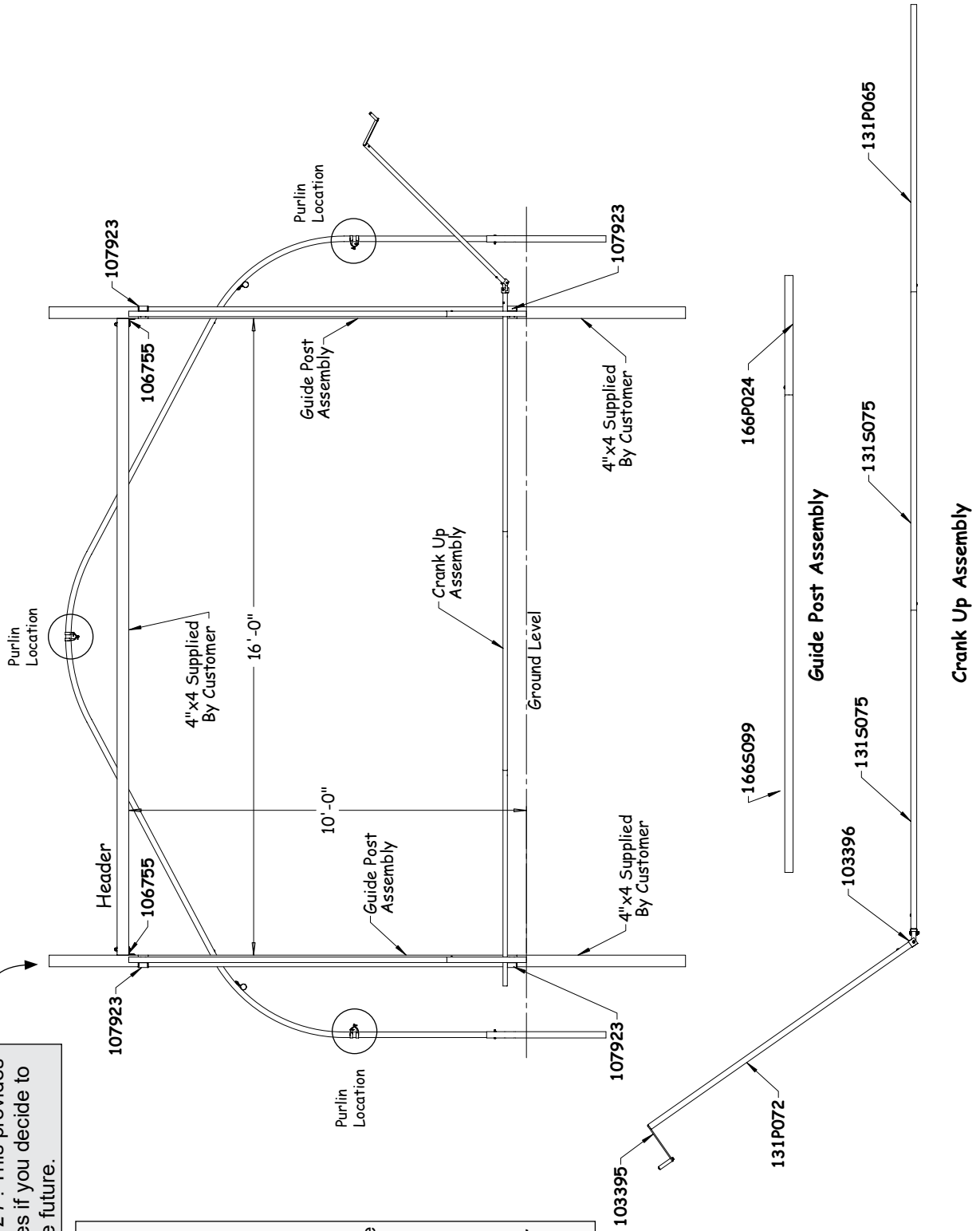

END FRAMING - CONNECTION DETAILS

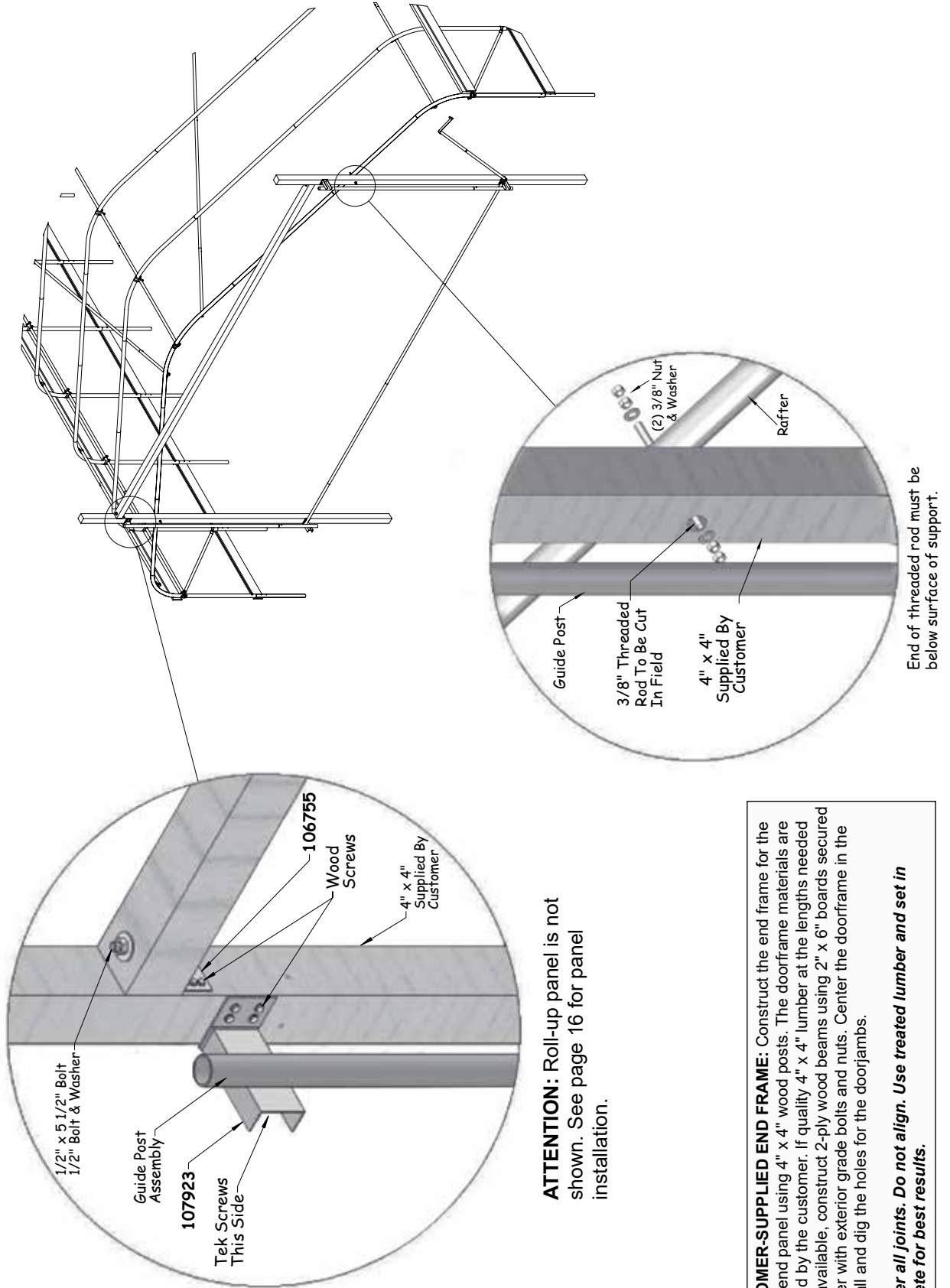

ATTENTION: Roll-up panel is not shown. See page 16 for panel installation.

CUSTOMER-SUPPLIED END FRAME: Construct the end frame for the roll-up end panel using 4" x 4" wood posts. The doorframe materials are supplied by the customer. If quality 4" x 4" lumber at the lengths needed is not available, construct 2-ply wood beams using 2" x 6" boards secured together with exterior grade bolts and nuts. Center the doorframe in the end wall and dig the holes for the doorjamb.

Stagger all joints. Do not align. Use treated lumber and set in concrete for best results.

End of threaded rod must be below surface of support.

END PANEL LOCATION DIAGRAM

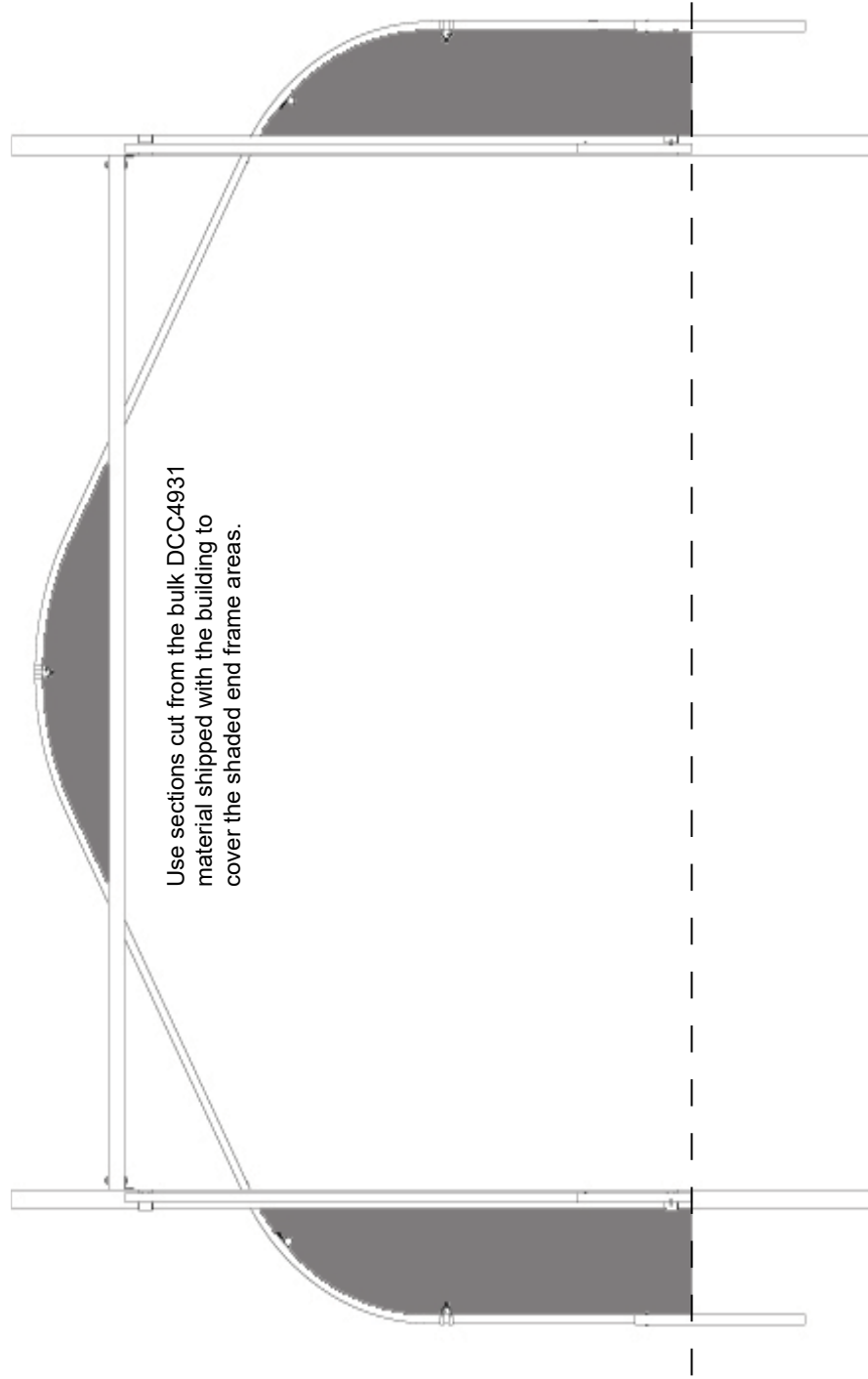

ATTENTION: The shaded areas above identify where to install the end panel material. Measure each area, cut a section from the bulk DCC4931 material, and attach the material to the end frame.

For best results, cut a rectangular piece of material to cover a section and trim the piece to size after attaching it to the frame.

DOOR FRAME PANEL LOCATION DIAGRAM

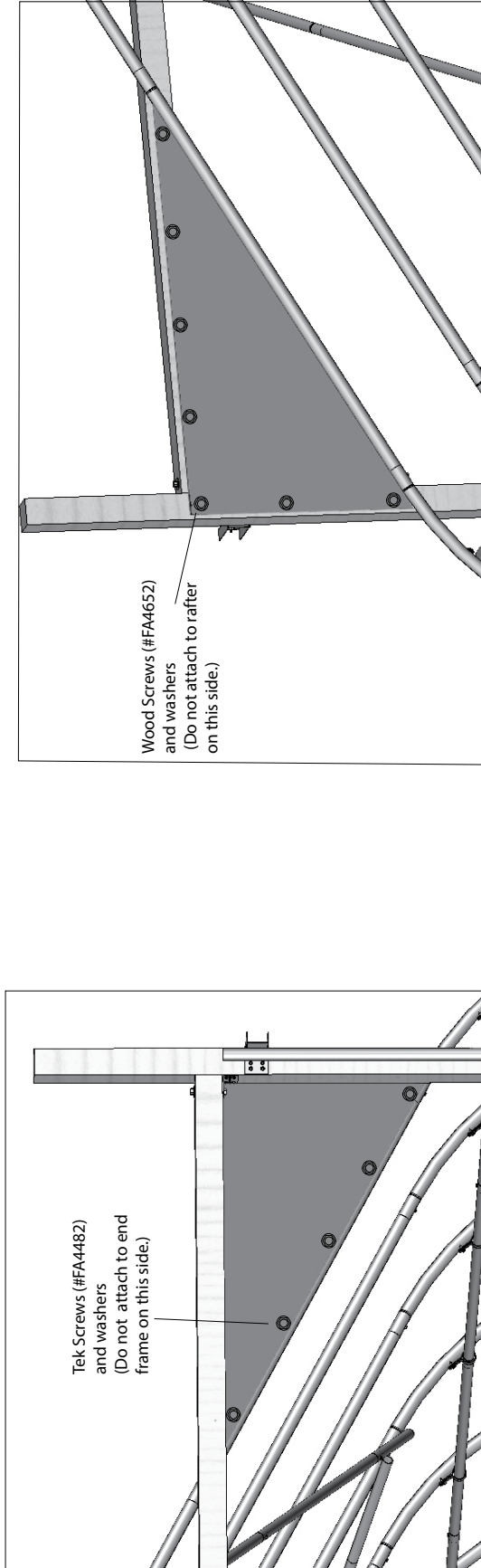

Front View

Back View

Use sections cut from the bulk DCC4931 material shipped with the building to cover the shaded door frame areas.

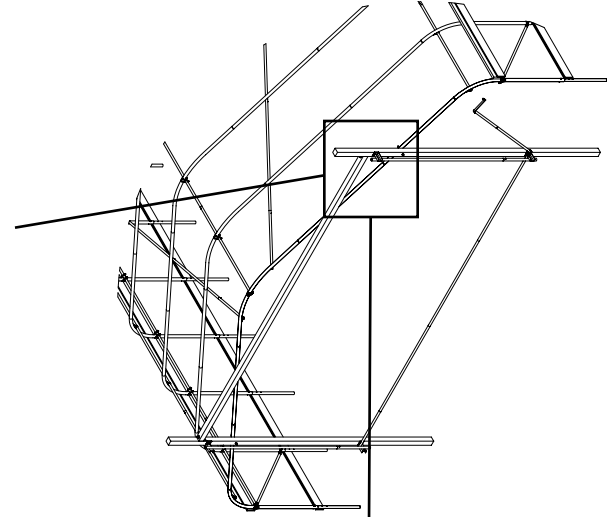

ATTENTION: The shaded areas above identify where to install the door frame panel material. Measure each area, cut a section from the bulk DCC4931 material, and attach the material to the end frame.

For best results, cut a rectangular piece of material to cover a section and trim the piece to size after attaching it to the frame.

CONNECTION - DROP-DOWN CURTAIN

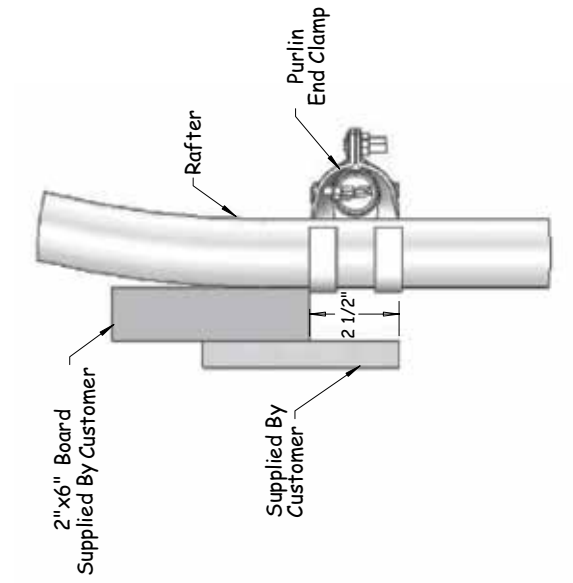

View 7
Purlin-End Rafter
Connection

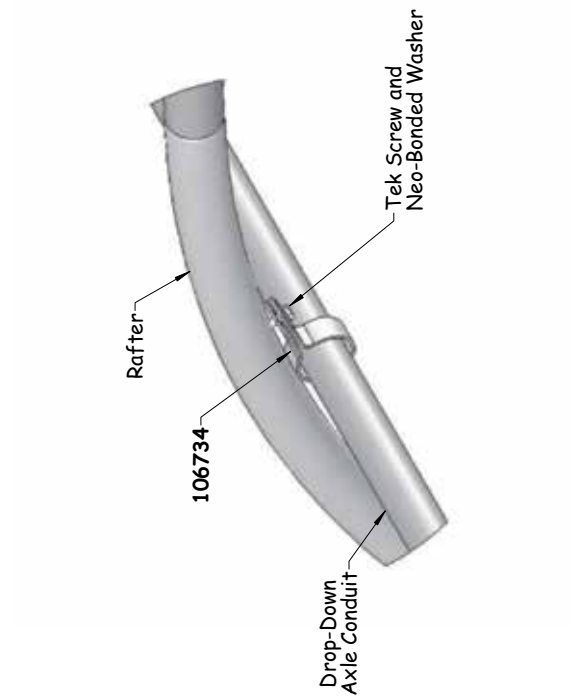

View 6
Drop-Down Axle Conduit-
Middle Rafter
Connection

MAIN COVER DETAILS

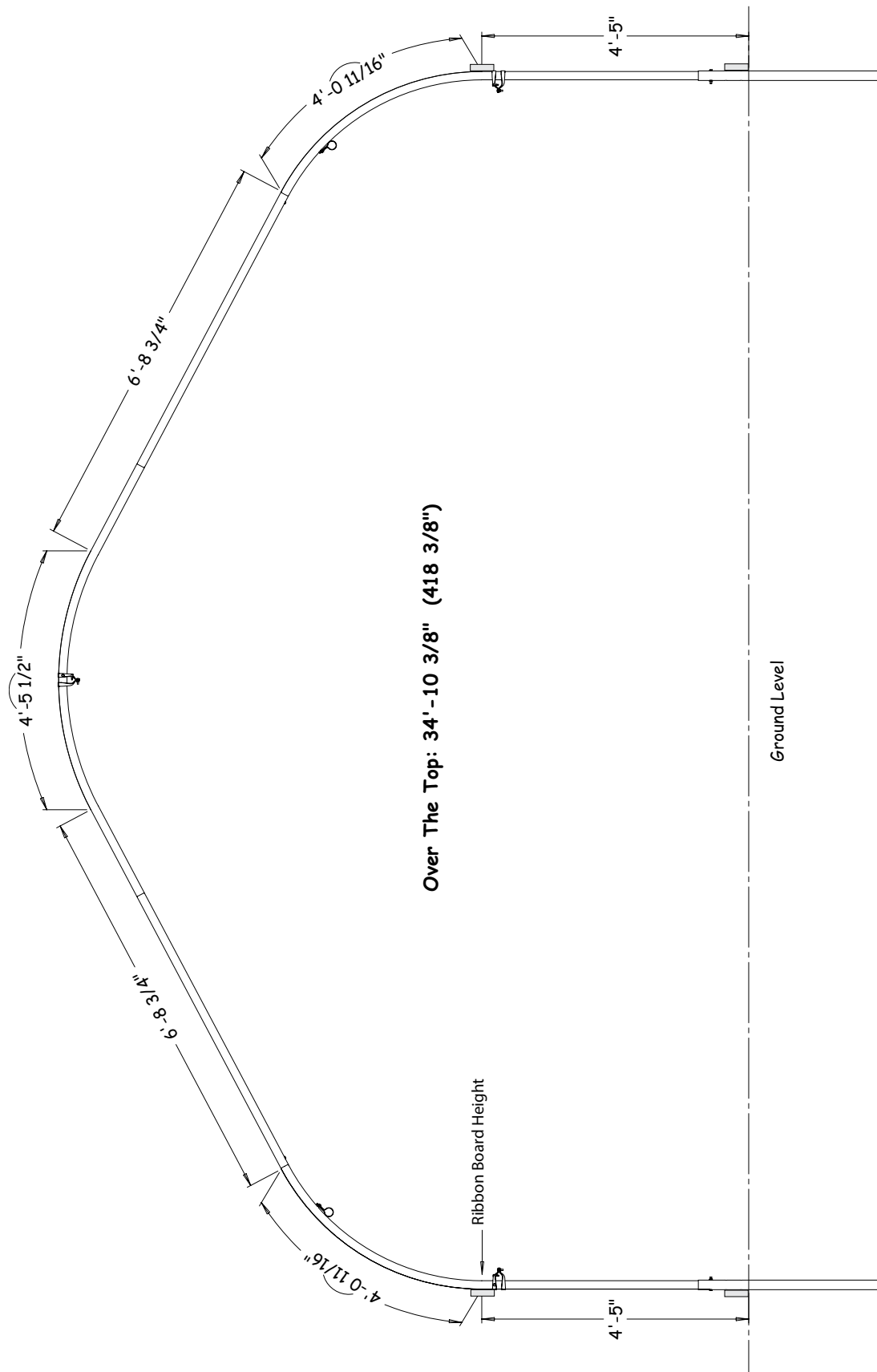

Suggestions: Winterizing the High Tunnel

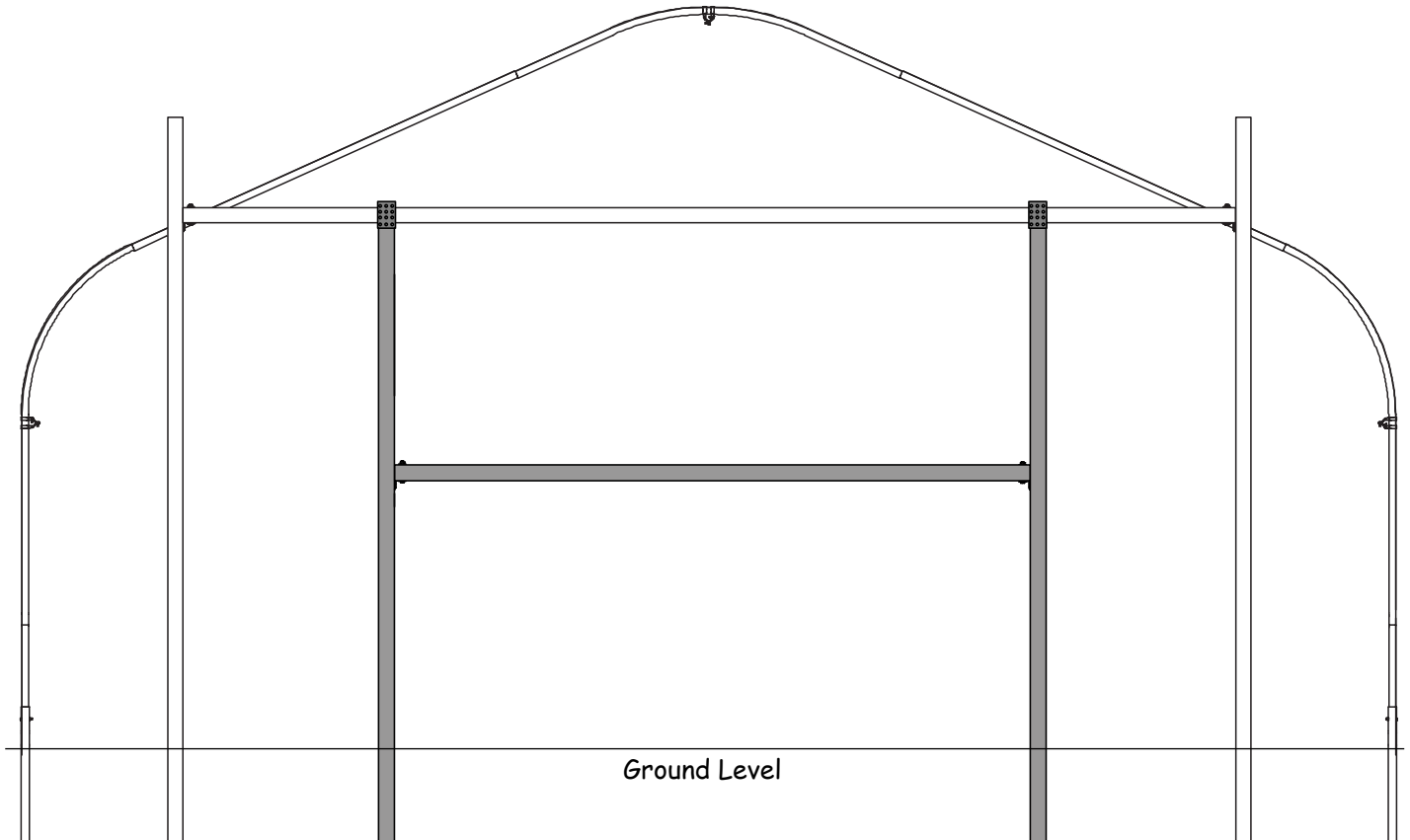

Using customer-supplied materials, create "H" bracing within the roll-up end panel frame to support the panel during winter months and strong winds. Secure horizontal support using pins for easy removal. Vertical bracing can remain throughout the year if spaced according to needs.

For added cold protection below ground, bury 2" foam insulation board down to the frost line around the perimeter of the building. Consult a qualified construction contractor **before erecting the high tunnel*** to determine how best to install the customer-supplied 2" insulation board.

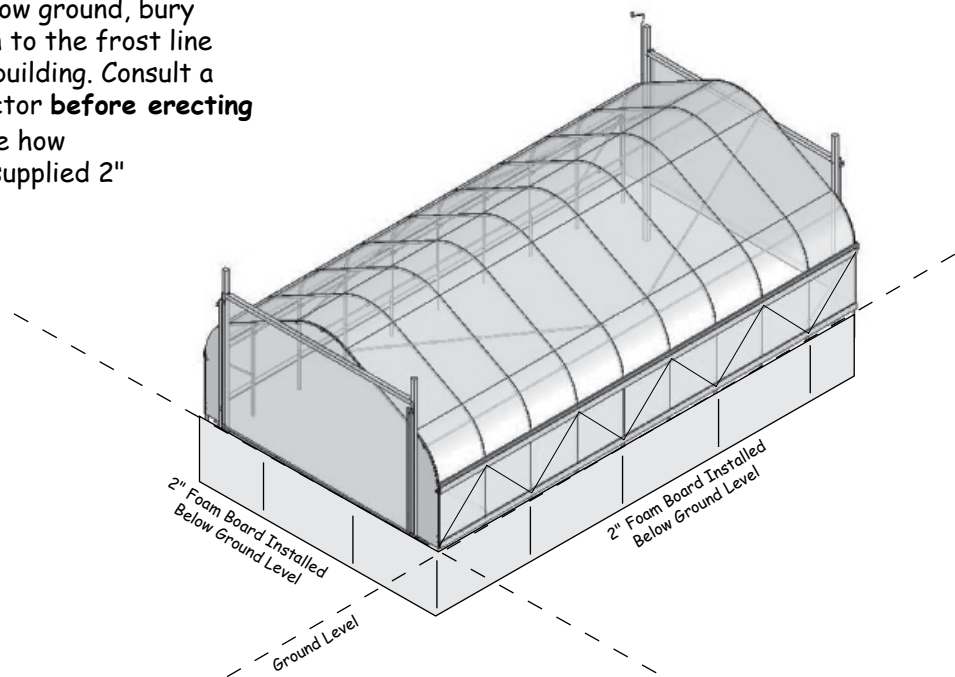

*Actual high tunnel may differ.